

R&S®FSMR

Measuring Receiver

Getting Started



1313.9698.02 – 01

The Quick Start Guide describes the following R&S®FSMR models and options:

- R&S FSMR3 1313.9200.03 with CF Card (R&S FSU-B18)
- R&S FSMR26 1313.9200.26 with CF Card (R&S FSU-B18)
- R&S FSMR43 1313.9200.43 with CF Card (R&S FSU-B18)
- R&S FSMR50 1313.9200.50 with CF Card (R&S FSU-B18)
- R&S FSMR3 1166.3311.03 with 3.5 disk drive, 1.44 MByte
- R&S FSMR26 1166.3311.26 with 3.5 disk drive, 1.44 MByte
- R&S FSMR43 1166.3311.43 with 3.5 disk drive, 1.44 MByte
- R&S FSMR50 1166.3311.50 with 3.5 disk drive, 1.44 MByte

The firmware of the instrument makes use of several valuable open source software packages. The most important of them are listed below, together with their corresponding open source license. The verbatim license texts are provided on the user documentation CD-ROM (included in delivery).

Package	Link	License
Xitami	http://www.xitami.com	2.5b6
PHP	http://www.php.net	PHP v 3
DOJO-AJAX	http://www.dojotoolkit.org	BSD License
BOOST Library	http://www.boost.org	Boost Software v.1
ONC/RPC	http://www.plt.rwth-aachen.de	SUN
TightVnc	http://www.tightvnc.com	GPL v.3
DemoForgeMirageDriver	http://www.demoforge.com/dfmirage.htm	GPL v.3

Rohde&Schwarz would like to thank the open source community for their valuable contribution to embedded computing.

© 2009 Rohde & Schwarz GmbH & Co. KG

81671 Munich, Germany

Printed in Germany – Subject to change – Data without tolerance limits is not binding.

R&S® is a registered trademark of Rohde & Schwarz GmbH & Co. KG.

Trade names are trademarks of the owners.

The following abbreviations are used throughout this manual:

R&S®FSMR is abbreviated as R&S FSMR.

Tabbed Divider Overview

Contents

Safety Instructions
Certificate of Quality
EU Certificate of Conformity
List of R&S Representatives

Manuals for Measuring Receiver R&S FSMR

Tabbed Divider

Chapter 1: Putting into Operation

Chapter 2: Getting Started

Chapter 3: Menu Overview

Index

Basic Safety Instructions

Always read through and comply with the following safety instructions!









All plants and locations of the Rohde & Schwarz group of companies make every effort to keep the safety standards of our products up to date and to offer our customers the highest possible degree of safety. Our products and the auxiliary equipment they require are designed, built and tested in accordance with the safety standards that apply in each case. Compliance with these standards is continuously monitored by our quality assurance system. The product described here has been designed, built and tested in accordance with the attached EC Certificate of Conformity and has left the manufacturer's plant in a condition fully complying with safety standards. To maintain this condition and to ensure safe operation, you must observe all instructions and warnings provided in this manual. If you have any questions regarding these safety instructions, the Rohde & Schwarz group of companies will be happy to answer them.







Furthermore, it is your responsibility to use the product in an appropriate manner. This product is designed for use solely in industrial and laboratory environments or, if expressly permitted, also in the field and must not be used in any way that may cause personal injury or property damage. You are responsible if the product is used for any intention other than its designated purpose or in disregard of the manufacturer's instructions. The manufacturer shall assume no responsibility for such use of the product.

The product is used for its designated purpose if it is used in accordance with its product documentation and within its performance limits (see data sheet, documentation, the following safety instructions). Using the product requires technical skills and a basic knowledge of English. It is therefore essential that only skilled and specialized staff or thoroughly trained personnel with the required skills be allowed to use the product. If personal safety gear is required for using Rohde & Schwarz products, this will be indicated at the appropriate place in the product documentation. Keep the basic safety instructions and the product documentation in a safe place and pass them on to the subsequent users.

Observing the safety instructions will help prevent personal injury or damage of any kind caused by dangerous situations. Therefore, carefully read through and adhere to the following safety instructions before and when using the product. It is also absolutely essential to observe the additional safety instructions on personal safety, for example, that appear in relevant parts of the product documentation. In these safety instructions, the word "product" refers to all merchandise sold and distributed by the Rohde & Schwarz group of companies, including instruments, systems and all accessories.

Symbols and safety labels

							
Notice, general danger location Observe product documentation	Caution when handling heavy equipment	Danger of electric shock	Warning! Hot surface	PE terminal	Ground	Ground terminal	Be careful when handling electrostatic sensitive devices

					
ON/OFF supply voltage	Standby indication	Direct current (DC)	Alternating current (AC)	Direct/alternating current (DC/AC)	Device fully protected by double (reinforced) insulation

Tags and their meaning

The following signal words are used in the product documentation in order to warn the reader about risks and dangers.



indicates a hazardous situation which, if not avoided, will result in death or serious injury.



indicates a hazardous situation which, if not avoided, could result in death or serious injury.



indicates a hazardous situation which, if not avoided, could result in minor or moderate injury.



indicates the possibility of incorrect operation which can result in damage to the product.

In the product documentation, the word ATTENTION is used synonymously.

These tags are in accordance with the standard definition for civil applications in the European Economic Area. Definitions that deviate from the standard definition may also exist in other economic areas or military applications. It is therefore essential to make sure that the tags described here are always used only in connection with the related product documentation and the related product. The use of tags in connection with unrelated products or documentation can result in misinterpretation and in personal injury or material damage.

Operating states and operating positions

The product may be operated only under the operating conditions and in the positions specified by the manufacturer, without the product's ventilation being obstructed. If the manufacturer's specifications are not observed, this can result in electric shock, fire and/or serious personal injury or death. Applicable local or national safety regulations and rules for the prevention of accidents must be observed in all work performed.

1. Unless otherwise specified, the following requirements apply to Rohde & Schwarz products: predefined operating position is always with the housing floor facing down, IP protection 2X, pollution severity 2, overvoltage category 2, use only indoors, max. operating altitude 2000 m above sea level, max. transport altitude 4500 m above sea level. A tolerance of $\pm 10\%$ shall apply to the nominal voltage and $\pm 5\%$ to the nominal frequency.
2. Do not place the product on surfaces, vehicles, cabinets or tables that for reasons of weight or stability are unsuitable for this purpose. Always follow the manufacturer's installation instructions when installing the product and fastening it to objects or structures (e.g. walls and shelves). An installation that is not carried out as described in the product documentation could result in personal injury or death.
3. Do not place the product on heat-generating devices such as radiators or fan heaters. The ambient temperature must not exceed the maximum temperature specified in the product documentation or in the data sheet. Product overheating can cause electric shock, fire and/or serious personal injury or death.

Electrical safety

If the information on electrical safety is not observed either at all to the extent necessary, electric shock, fire and/or serious personal injury or death may occur.

1. Prior to switching on the product, always ensure that the nominal voltage setting on the product matches the nominal voltage of the AC supply network. If a different voltage is to be set, the power fuse of the product may have to be changed accordingly.
2. In the case of products of safety class I with movable power cord and connector, operation is permitted only on sockets with an earthing contact and protective earth connection.
3. Intentionally breaking the protective earth connection either in the feed line or in the product itself is not permitted. Doing so can result in the danger of an electric shock from the product. If extension cords or connector strips are implemented, they must be checked on a regular basis to ensure that they are safe to use.
4. If the product does not have a power switch for disconnection from the AC supply network, the plug of the connecting cable is regarded as the disconnecting device. In such cases, always ensure that the power plug is easily reachable and accessible at all times (corresponding to the length of connecting cable, approx. 2 m). Functional or electronic switches are not suitable for providing disconnection from the AC supply network. If products without power switches are integrated into racks or systems, a disconnecting device must be provided at the system level.
5. Never use the product if the power cable is damaged. Check the power cable on a regular basis to ensure that it is in proper operating condition. By taking appropriate safety measures and carefully laying the power cable, you can ensure that the cable will not be damaged and that no one can be hurt by, for example, tripping over the cable or suffering an electric shock.
6. The product may be operated only from TN/TT supply networks fused with max. 16 A (higher fuse only after consulting with the Rohde & Schwarz group of companies).
7. Do not insert the plug into sockets that are dusty or dirty. Insert the plug firmly and all the way into the socket. Otherwise, sparks that result in fire and/or injuries may occur.
8. Do not overload any sockets, extension cords or connector strips; doing so can cause fire or electric shocks.
9. For measurements in circuits with voltages $V_{\text{rms}} > 30 \text{ V}$, suitable measures (e.g. appropriate measuring equipment, fusing, current limiting, electrical separation, insulation) should be taken to avoid any hazards.
10. Ensure that the connections with information technology equipment, e.g. PCs or other industrial computers, comply with the IEC60950-1/EN60950-1 or IEC61010-1/EN 61010-1 standards that apply in each case.
11. Unless expressly permitted, never remove the cover or any part of the housing while the product is in operation. Doing so will expose circuits and components and can lead to injuries, fire or damage to the product.
12. If a product is to be permanently installed, the connection between the PE terminal on site and the product's PE conductor must be made first before any other connection is made. The product may be installed and connected only by a licensed electrician.
13. For permanently installed equipment without built-in fuses, circuit breakers or similar protective devices, the supply circuit must be fused in such a way that anyone who has access to the product, as well as the product itself, is adequately protected from injury or damage.

14. Use suitable overvoltage protection to ensure that no overvoltage (such as that caused by a bolt of lightning) can reach the product. Otherwise, the person operating the product will be exposed to the danger of an electric shock.
15. Any object that is not designed to be placed in the openings of the housing must not be used for this purpose. Doing so can cause short circuits inside the product and/or electric shocks, fire or injuries.
16. Unless specified otherwise, products are not liquid-proof (see also section "Operating states and operating positions", item 1. Therefore, the equipment must be protected against penetration by liquids. If the necessary precautions are not taken, the user may suffer electric shock or the product itself may be damaged, which can also lead to personal injury.
17. Never use the product under conditions in which condensation has formed or can form in or on the product, e.g. if the product has been moved from a cold to a warm environment. Penetration by water increases the risk of electric shock.
18. Prior to cleaning the product, disconnect it completely from the power supply (e.g. AC supply network or battery). Use a soft, non-linting cloth to clean the product. Never use chemical cleaning agents such as alcohol, acetone or diluents for cellulose lacquers.

Operation

1. Operating the products requires special training and intense concentration. Make sure that persons who use the products are physically, mentally and emotionally fit enough to do so; otherwise, injuries or material damage may occur. It is the responsibility of the employer/operator to select suitable personnel for operating the products.
2. Before you move or transport the product, read and observe the section titled "Transport".
3. As with all industrially manufactured goods, the use of substances that induce an allergic reaction (allergens) such as nickel cannot be generally excluded. If you develop an allergic reaction (such as a skin rash, frequent sneezing, red eyes or respiratory difficulties) when using a Rohde & Schwarz product, consult a physician immediately to determine the cause and to prevent health problems or stress.
4. Before you start processing the product mechanically and/or thermally, or before you take it apart, be sure to read and pay special attention to the section titled "Waste disposal", item 1.
5. Depending on the function, certain products such as RF radio equipment can produce an elevated level of electromagnetic radiation. Considering that unborn babies require increased protection, pregnant women must be protected by appropriate measures. Persons with pacemakers may also be exposed to risks from electromagnetic radiation. The employer/operator must evaluate workplaces where there is a special risk of exposure to radiation and, if necessary, take measures to avert the potential danger.
6. Should a fire occur, the product may release hazardous substances (gases, fluids, etc.) that can cause health problems. Therefore, suitable measures must be taken, e.g. protective masks and protective clothing must be worn.
7. If a laser product (e.g. a CD/DVD drive) is integrated into a Rohde & Schwarz product, absolutely no other settings or functions may be used as described in the product documentation. The objective is to prevent personal injury (e.g. due to laser beams).

Repair and service

1. The product may be opened only by authorized, specially trained personnel. Before any work is performed on the product or before the product is opened, it must be disconnected from the AC supply network. Otherwise, personnel will be exposed to the risk of an electric shock.
2. Adjustments, replacement of parts, maintenance and repair may be performed only by electrical experts authorized by Rohde & Schwarz. Only original parts may be used for replacing parts relevant to safety (e.g. power switches, power transformers, fuses). A safety test must always be performed after parts relevant to safety have been replaced (visual inspection, PE conductor test, insulation resistance measurement, leakage current measurement, functional test). This helps ensure the continued safety of the product.

Batteries and rechargeable batteries/cells

If the information regarding batteries and rechargeable batteries/cells is not observed either at all or to the extent necessary, product users may be exposed to the risk of explosions, fire and/or serious personal injury, and, in some cases, death. Batteries and rechargeable batteries with alkaline electrolytes (e.g. lithium cells) must be handled in accordance with the EN 62133 standard.

1. Cells must not be taken apart or crushed.
2. Cells or batteries must not be exposed to heat or fire. Storage in direct sunlight must be avoided. Keep cells and batteries clean and dry. Clean soiled connectors using a dry, clean cloth.
3. Cells or batteries must not be short-circuited. Cells or batteries must not be stored in a box or in a drawer where they can short-circuit each other, or where they can be short-circuited by other conductive materials. Cells and batteries must not be removed from their original packaging until they are ready to be used.
4. Keep cells and batteries out of the hands of children. If a cell or a battery has been swallowed, seek medical aid immediately.
5. Cells and batteries must not be exposed to any mechanical shocks that are stronger than permitted.
6. If a cell develops a leak, the fluid must not be allowed to come into contact with the skin or eyes. If contact occurs, wash the affected area with plenty of water and seek medical aid.
7. Improperly replacing or charging cells or batteries that contain alkaline electrolytes (e.g. lithium cells) can cause explosions. Replace cells or batteries only with the matching Rohde & Schwarz type (see parts list) in order to ensure the safety of the product.
8. Cells and batteries must be recycled and kept separate from residual waste. Rechargeable batteries and normal batteries that contain lead, mercury or cadmium are hazardous waste. Observe the national regulations regarding waste disposal and recycling.

Transport

1. The product may be very heavy. Therefore, the product must be handled with care. In some cases, the user may require a suitable means of lifting or moving the product (e.g. with a lift-truck) to avoid back or other physical injuries.

2. Handles on the products are designed exclusively to enable personnel to transport the product. It is therefore not permissible to use handles to fasten the product to or on transport equipment such as cranes, fork lifts, wagons, etc. The user is responsible for securely fastening the products to or on the means of transport or lifting. Observe the safety regulations of the manufacturer of the means of transport or lifting. Noncompliance can result in personal injury or material damage.
3. If you use the product in a vehicle, it is the sole responsibility of the driver to drive the vehicle safely and properly. The manufacturer assumes no responsibility for accidents or collisions. Never use the product in a moving vehicle if doing so could distract the driver of the vehicle. Adequately secure the product in the vehicle to prevent injuries or other damage in the event of an accident.

Waste disposal

1. If products or their components are mechanically and/or thermally processed in a manner that goes beyond their intended use, hazardous substances (heavy-metal dust such as lead, beryllium, nickel) may be released. For this reason, the product may only be disassembled by specially trained personnel. Improper disassembly may be hazardous to your health. National waste disposal regulations must be observed.
2. If handling the product releases hazardous substances or fuels that must be disposed of in a special way, e.g. coolants or engine oils that must be replenished regularly, the safety instructions of the manufacturer of the hazardous substances or fuels and the applicable regional waste disposal regulations must be observed. Also observe the relevant safety instructions in the product documentation. The improper disposal of hazardous substances or fuels can cause health problems and lead to environmental damage.

Informaciones elementales de seguridad

Es imprescindible leer y observar las siguientes instrucciones e informaciones de seguridad!









El principio del grupo de empresas Rohde & Schwarz consiste en tener nuestros productos siempre al día con los estándares de seguridad y de ofrecer a nuestros clientes el máximo grado de seguridad. Nuestros productos y todos los equipos adicionales son siempre fabricados y examinados según las normas de seguridad vigentes. Nuestro sistema de garantía de calidad controla constantemente que sean cumplidas estas normas. El presente producto ha sido fabricado y examinado según el certificado de conformidad adjunto de la UE y ha salido de nuestra planta en estado impecable según los estándares técnicos de seguridad. Para poder preservar este estado y garantizar un funcionamiento libre de peligros, el usuario deberá atenerse a todas las indicaciones, informaciones de seguridad y notas de alerta. El grupo de empresas Rohde & Schwarz está siempre a su disposición en caso de que tengan preguntas referentes a estas informaciones de seguridad.







Además queda en la responsabilidad del usuario utilizar el producto en la forma debida. Este producto está destinado exclusivamente al uso en la industria y el laboratorio o, si ha sido expresamente autorizado, para aplicaciones de campo y de ninguna manera deberá ser utilizado de modo que alguna persona/cosa pueda sufrir daño. El uso del producto fuera de sus fines definidos o sin tener en cuenta las instrucciones del fabricante queda en la responsabilidad del usuario. El fabricante no se hace en ninguna forma responsable de consecuencias a causa del mal uso del producto.

Se parte del uso correcto del producto para los fines definidos si el producto es utilizado conforme a las indicaciones de la correspondiente documentación del producto y dentro del margen de rendimiento definido (ver hoja de datos, documentación, informaciones de seguridad que siguen). El uso del producto hace necesarios conocimientos técnicos y ciertos conocimientos del idioma inglés. Por eso se debe tener en cuenta que el producto solo pueda ser operado por personal especializado o personas instruidas en profundidad con las capacidades correspondientes. Si fuera necesaria indumentaria de seguridad para el uso de productos de Rohde & Schwarz, encontraría la información debida en la documentación del producto en el capítulo correspondiente. Guarde bien las informaciones de seguridad elementales, así como la documentación del producto, y entréguelas a usuarios posteriores.

Tener en cuenta las informaciones de seguridad sirve para evitar en lo posible lesiones o daños por peligros de toda clase. Por eso es imprescindible leer detalladamente y comprender por completo las siguientes informaciones de seguridad antes de usar el producto, y respetarlas durante el uso del producto. Deberán tenerse en cuenta todas las demás informaciones de seguridad, como p. ej. las referentes a la protección de personas, que encontrarán en el capítulo correspondiente de la documentación del producto y que también son de obligado cumplimiento. En las presentes informaciones de seguridad se recogen todos los objetos que distribuye el grupo de empresas Rohde & Schwarz bajo la denominación de "producto", entre ellos también aparatos, instalaciones así como toda clase de accesorios.

Símbolos y definiciones de seguridad

							
Aviso: punto de peligro general Observar la documentación del producto	Atención en el manejo de dispositivos de peso elevado	Peligro de choque eléctrico	Advertencia: superficie caliente	Conexión a conductor de protección	Conexión a tierra	Conexión a masa	Aviso: Cuidado en el manejo de dispositivos sensibles a la electrostática (ESD)

					
Tensión de alimentación de PUESTA EN MARCHA / PARADA	Indicación de estado de espera (Standby)	Corriente continua (DC)	Corriente alterna (AC)	Corriente continua / Corriente alterna (DC/AC)	El aparato está protegido en su totalidad por un aislamiento doble (reforzado)

Palabras de señal y su significado

En la documentación del producto se utilizan las siguientes palabras de señal con el fin de advertir contra riesgos y peligros.



PELIGRO identifica un peligro inminente con riesgo elevado que provocará muerte o lesiones graves si no se evita.



ADVERTENCIA identifica un posible peligro con riesgo medio de provocar muerte o lesiones (graves) si no se evita.



ATENCIÓN identifica un peligro con riesgo reducido de provocar lesiones leves o moderadas si no se evita.



AVISO indica la posibilidad de utilizar mal el producto y, como consecuencia, dañarlo.

En la documentación del producto se emplea de forma sinónima el término CUIDADO.

Las palabras de señal corresponden a la definición habitual para aplicaciones civiles en el área económica europea. Pueden existir definiciones diferentes a esta definición en otras áreas económicas o en aplicaciones militares. Por eso se deberá tener en cuenta que las palabras de señal aquí descritas sean utilizadas siempre solamente en combinación con la correspondiente documentación del producto y solamente en combinación con el producto correspondiente. La utilización de las palabras de señal en combinación con productos o documentaciones que no les correspondan puede llevar a interpretaciones equivocadas y tener por consecuencia daños en personas u objetos.

Estados operativos y posiciones de funcionamiento

El producto solamente debe ser utilizado según lo indicado por el fabricante respecto a los estados operativos y posiciones de funcionamiento sin que se obstruya la ventilación. Si no se siguen las indicaciones del fabricante, pueden producirse choques eléctricos, incendios y/o lesiones graves con posible consecuencia de muerte. En todos los trabajos deberán ser tenidas en cuenta las normas nacionales y locales de seguridad del trabajo y de prevención de accidentes.

1. Si no se convino de otra manera, es para los productos Rohde & Schwarz válido lo que sigue: como posición de funcionamiento se define por principio la posición con el suelo de la caja para abajo, modo de protección IP 2X, grado de suciedad 2, categoría de sobrecarga eléctrica 2, uso solamente en estancias interiores, utilización hasta 2000 m sobre el nivel del mar, transporte hasta 4500 m sobre el nivel del mar. Se aplicará una tolerancia de $\pm 10\%$ sobre el voltaje nominal y de $\pm 5\%$ sobre la frecuencia nominal.
2. No sitúe el producto encima de superficies, vehículos, estantes o mesas, que por sus características de peso o de estabilidad no sean aptos para él. Siga siempre las instrucciones de instalación del fabricante cuando instale y asegure el producto en objetos o estructuras (p. ej. paredes y estantes). Si se realiza la instalación de modo distinto al indicado en la documentación del producto, pueden causarse lesiones o incluso la muerte.
3. No ponga el producto sobre aparatos que generen calor (p. ej. radiadores o calefactores). La temperatura ambiente no debe superar la temperatura máxima especificada en la documentación del producto o en la hoja de datos. En caso de sobrecalentamiento del producto, pueden producirse choques eléctricos, incendios y/o lesiones graves con posible consecuencia de muerte.

Seguridad eléctrica

Si no se siguen (o se siguen de modo insuficiente) las indicaciones del fabricante en cuanto a seguridad eléctrica, pueden producirse choques eléctricos, incendios y/o lesiones graves con posible consecuencia de muerte.

1. Antes de la puesta en marcha del producto se deberá comprobar siempre que la tensión preseleccionada en el producto coincida con la de la red de alimentación eléctrica. Si es necesario modificar el ajuste de tensión, también se deberán cambiar en caso dado los fusibles correspondientes del producto.
2. Los productos de la clase de protección I con alimentación móvil y enchufe individual solamente podrán enchufarse a tomas de corriente con contacto de seguridad y con conductor de protección conectado.
3. Queda prohibida la interrupción intencionada del conductor de protección, tanto en la toma de corriente como en el mismo producto. La interrupción puede tener como consecuencia el riesgo de que el producto sea fuente de choques eléctricos. Si se utilizan cables alargadores o regletas de enchufe, deberá garantizarse la realización de un examen regular de los mismos en cuanto a su estado técnico de seguridad.
4. Si el producto no está equipado con un interruptor para desconectarlo de la red, se deberá considerar el enchufe del cable de conexión como interruptor. En estos casos se deberá asegurar que el enchufe siempre sea de fácil acceso (de acuerdo con la longitud del cable de conexión, aproximadamente 2 m). Los interruptores de función o electrónicos no son aptos para el corte de la red eléctrica. Si los productos sin interruptor están integrados en bastidores o instalaciones, se deberá colocar el interruptor en el nivel de la instalación.
5. No utilice nunca el producto si está dañado el cable de conexión a red. Compruebe regularmente el correcto estado de los cables de conexión a red. Asegúrese, mediante las medidas de protección y de instalación adecuadas, de que el cable de conexión a red no pueda ser dañado o de que nadie pueda ser dañado por él, p. ej. al tropezar o por un choque eléctrico.
6. Solamente está permitido el funcionamiento en redes de alimentación TN/TT aseguradas con fusibles de 16 A como máximo (utilización de fusibles de mayor amperaje solo previa consulta con el grupo de empresas Rohde & Schwarz).
7. Nunca conecte el enchufe en tomas de corriente sucias o llenas de polvo. Introduzca el enchufe por completo y fuertemente en la toma de corriente. La no observación de estas medidas puede provocar chispas, fuego y/o lesiones.
8. No sobrecargue las tomas de corriente, los cables alargadores o las regletas de enchufe ya que esto podría causar fuego o choques eléctricos.
9. En las mediciones en circuitos de corriente con una tensión $U_{\text{eff}} > 30 \text{ V}$ se deberán tomar las medidas apropiadas para impedir cualquier peligro (p. ej. medios de medición adecuados, seguros, limitación de tensión, corte protector, aislamiento etc.).
10. Para la conexión con dispositivos informáticos como un PC o un ordenador industrial, debe comprobarse que éstos cumplan los estándares IEC60950-1/EN60950-1 o IEC61010-1/EN 61010-1 válidos en cada caso.
11. A menos que esté permitido expresamente, no retire nunca la tapa ni componentes de la carcasa mientras el producto esté en servicio. Esto pone a descubierto los cables y componentes eléctricos y puede causar lesiones, fuego o daños en el producto.

12. Si un producto se instala en un lugar fijo, se deberá primero conectar el conductor de protección fijo con el conductor de protección del producto antes de hacer cualquier otra conexión. La instalación y la conexión deberán ser efectuadas por un electricista especializado.
13. En el caso de dispositivos fijos que no estén provistos de fusibles, interruptor automático ni otros mecanismos de seguridad similares, el circuito de alimentación debe estar protegido de modo que todas las personas que puedan acceder al producto, así como el producto mismo, estén a salvo de posibles daños.
14. Todo producto debe estar protegido contra sobretensión (debida p. ej. a una caída del rayo) mediante los correspondientes sistemas de protección. Si no, el personal que lo utilice quedará expuesto al peligro de choque eléctrico.
15. No debe introducirse en los orificios de la caja del aparato ningún objeto que no esté destinado a ello. Esto puede producir cortocircuitos en el producto y/o puede causar choques eléctricos, fuego o lesiones.
16. Salvo indicación contraria, los productos no están impermeabilizados (ver también el capítulo "Estados operativos y posiciones de funcionamiento", punto 1). Por eso es necesario tomar las medidas necesarias para evitar la entrada de líquidos. En caso contrario, existe peligro de choque eléctrico para el usuario o de daños en el producto, que también pueden redundar en peligro para las personas.
17. No utilice el producto en condiciones en las que pueda producirse o ya se hayan producido condensaciones sobre el producto o en el interior de éste, como p. ej. al desplazarlo de un lugar frío a otro caliente. La entrada de agua aumenta el riesgo de choque eléctrico.
18. Antes de la limpieza, desconecte por completo el producto de la alimentación de tensión (p. ej. red de alimentación o batería). Realice la limpieza de los aparatos con un paño suave, que no se deshilache. No utilice bajo ningún concepto productos de limpieza químicos como alcohol, acetona o diluyentes para lacas nitrocelulósicas.

Funcionamiento

1. El uso del producto requiere instrucciones especiales y una alta concentración durante el manejo. Debe asegurarse que las personas que manejen el producto estén a la altura de los requerimientos necesarios en cuanto a aptitudes físicas, psíquicas y emocionales, ya que de otra manera no se pueden excluir lesiones o daños de objetos. El empresario u operador es responsable de seleccionar el personal usuario apto para el manejo del producto.
2. Antes de desplazar o transportar el producto, lea y tenga en cuenta el capítulo "Transporte".
3. Como con todo producto de fabricación industrial no puede quedar excluida en general la posibilidad de que se produzcan alergias provocadas por algunos materiales empleados, los llamados alérgenos (p. ej. el níquel). Si durante el manejo de productos Rohde & Schwarz se producen reacciones alérgicas, como p. ej. irritaciones cutáneas, estornudos continuos, enrojecimiento de la conjuntiva o dificultades respiratorias, debe avisarse inmediatamente a un médico para investigar las causas y evitar cualquier molestia o daño a la salud.
4. Antes de la manipulación mecánica y/o térmica o el desmontaje del producto, debe tenerse en cuenta imprescindiblemente el capítulo "Eliminación", punto 1.

5. Ciertos productos, como p. ej. las instalaciones de radiocomunicación RF, pueden a causa de su función natural, emitir una radiación electromagnética aumentada. Deben tomarse todas las medidas necesarias para la protección de las mujeres embarazadas. También las personas con marcapasos pueden correr peligro a causa de la radiación electromagnética. El empresario/operador tiene la obligación de evaluar y señalar las áreas de trabajo en las que exista un riesgo elevado de exposición a radiaciones.
6. Tenga en cuenta que en caso de incendio pueden desprenderse del producto sustancias tóxicas (gases, líquidos etc.) que pueden generar daños a la salud. Por eso, en caso de incendio deben usarse medidas adecuadas, como p. ej. máscaras antigás e indumentaria de protección.
7. En caso de que un producto Rohde & Schwarz contenga un producto láser (p. ej. un lector de CD/DVD), no debe usarse ninguna otra configuración o función aparte de las descritas en la documentación del producto, a fin de evitar lesiones (p. ej. debidas a irradiación láser).

Reparación y mantenimiento

1. El producto solamente debe ser abierto por personal especializado con autorización para ello. Antes de manipular el producto o abrirlo, es obligatorio desconectarlo de la tensión de alimentación, para evitar toda posibilidad de choque eléctrico.
2. El ajuste, el cambio de partes, el mantenimiento y la reparación deberán ser efectuadas solamente por electricistas autorizados por Rohde & Schwarz. Si se reponen partes con importancia para los aspectos de seguridad (p. ej. el enchufe, los transformadores o los fusibles), solamente podrán ser sustituidos por partes originales. Después de cada cambio de partes relevantes para la seguridad deberá realizarse un control de seguridad (control a primera vista, control del conductor de protección, medición de resistencia de aislamiento, medición de la corriente de fuga, control de funcionamiento). Con esto queda garantizada la seguridad del producto.

Baterías y acumuladores o celdas

Si no se siguen (o se siguen de modo insuficiente) las indicaciones en cuanto a las baterías y acumuladores o celdas, pueden producirse explosiones, incendios y/o lesiones graves con posible consecuencia de muerte. El manejo de baterías y acumuladores con electrolitos alcalinos (p. ej. celdas de litio) debe seguir el estándar EN 62133.

1. No deben desmontarse, abrirse ni triturarse las celdas.
2. Las celdas o baterías no deben someterse a calor ni fuego. Debe evitarse el almacenamiento a la luz directa del sol. Las celdas y baterías deben mantenerse limpias y secas. Limpiar las conexiones sucias con un paño seco y limpio.
3. Las celdas o baterías no deben cortocircuitarse. Es peligroso almacenar las celdas o baterías en estuches o cajones en cuyo interior puedan cortocircuitarse por contacto recíproco o por contacto con otros materiales conductores. No deben extraerse las celdas o baterías de sus embalajes originales hasta el momento en que vayan a utilizarse.
4. Mantener baterías y celdas fuera del alcance de los niños. En caso de ingestión de una celda o batería, avisar inmediatamente a un médico.
5. Las celdas o baterías no deben someterse a impactos mecánicos fuertes indebidos.

6. En caso de falta de estanqueidad de una celda, el líquido vertido no debe entrar en contacto con la piel ni los ojos. Si se produce contacto, lavar con agua abundante la zona afectada y avisar a un médico.
7. En caso de cambio o recarga inadecuados, las celdas o baterías que contienen electrolitos alcalinos (p. ej. las celdas de litio) pueden explotar. Para garantizar la seguridad del producto, las celdas o baterías solo deben ser sustituidas por el tipo Rohde & Schwarz correspondiente (ver lista de recambios).
8. Las baterías y celdas deben reciclarse y no deben tirarse a la basura doméstica. Las baterías o acumuladores que contienen plomo, mercurio o cadmio deben tratarse como residuos especiales. Respete en esta relación las normas nacionales de eliminación y reciclaje.

Transporte

1. El producto puede tener un peso elevado. Por eso es necesario desplazarlo o transportarlo con precaución y, si es necesario, usando un sistema de elevación adecuado (p. ej. una carretilla elevadora), a fin de evitar lesiones en la espalda u otros daños personales.
2. Las asas instaladas en los productos sirven solamente de ayuda para el transporte del producto por personas. Por eso no está permitido utilizar las asas para la sujeción en o sobre medios de transporte como p. ej. grúas, carretillas elevadoras de horquilla, carros etc. Es responsabilidad suya fijar los productos de manera segura a los medios de transporte o elevación. Para evitar daños personales o daños en el producto, siga las instrucciones de seguridad del fabricante del medio de transporte o elevación utilizado.
3. Si se utiliza el producto dentro de un vehículo, recae de manera exclusiva en el conductor la responsabilidad de conducir el vehículo de manera segura y adecuada. El fabricante no asumirá ninguna responsabilidad por accidentes o colisiones. No utilice nunca el producto dentro de un vehículo en movimiento si esto pudiera distraer al conductor. Asegure el producto dentro del vehículo debidamente para evitar, en caso de un accidente, lesiones u otra clase de daños.

Eliminación

1. Si se trabaja de manera mecánica y/o térmica cualquier producto o componente más allá del funcionamiento previsto, pueden liberarse sustancias peligrosas (polvos con contenido de metales pesados como p. ej. plomo, berilio o níquel). Por eso el producto solo debe ser desmontado por personal especializado con formación adecuada. Un desmontaje inadecuado puede ocasionar daños para la salud. Se deben tener en cuenta las directivas nacionales referentes a la eliminación de residuos.
2. En caso de que durante el trato del producto se formen sustancias peligrosas o combustibles que deban tratarse como residuos especiales (p. ej. refrigerantes o aceites de motor con intervalos de cambio definidos), deben tenerse en cuenta las indicaciones de seguridad del fabricante de dichas sustancias y las normas regionales de eliminación de residuos. Tenga en cuenta también en caso necesario las indicaciones de seguridad especiales contenidas en la documentación del producto. La eliminación incorrecta de sustancias peligrosas o combustibles puede causar daños a la salud o daños al medio ambiente.

Kundeninformation zur Batterieverordnung (BattV)

Dieses Gerät enthält eine schadstoffhaltige Batterie. Diese darf nicht mit dem Hausmüll entsorgt werden.

Nach Ende der Lebensdauer darf die Entsorgung nur über eine Rohde&Schwarz-Kundendienststelle oder eine geeignete Sammelstelle erfolgen.

Safety Regulations for Batteries (according to BattV)

This equipment houses a battery containing harmful substances that must not be disposed of as normal household waste.

After its useful life, the battery may only be disposed of at a Rohde & Schwarz service center or at a suitable depot.

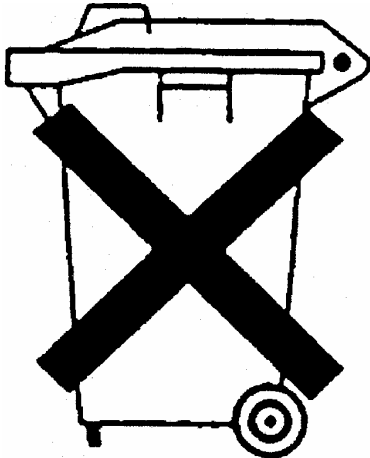

Normas de Seguridad para Baterías (Según BattV)

Este equipo lleva una batería que contiene sustancias perjudiciales, que no se debe desechar en los contenedores de basura domésticos.

Después de la vida útil, la batería sólo se podrá eliminar en un centro de servicio de Rohde & Schwarz o en un depósito apropiado.

Consignes de sécurité pour batteries (selon BattV)

Cet appareil est équipé d'une pile comprenant des substances nocives. Ne jamais la jeter dans une poubelle pour ordures ménagères.

Une pile usagée doit uniquement être éliminée par un centre de service client de Rohde & Schwarz ou peut être collectée pour être traitée spécialement comme déchets dangereux.

Customer Information Regarding Product Disposal

The German Electrical and Electronic Equipment (ElektroG) Act is an implementation of the following EC directives:

- 2002/96/EC on waste electrical and electronic equipment (WEEE) and
- 2002/95/EC on the restriction of the use of certain hazardous substances in electrical and electronic equipment (RoHS).

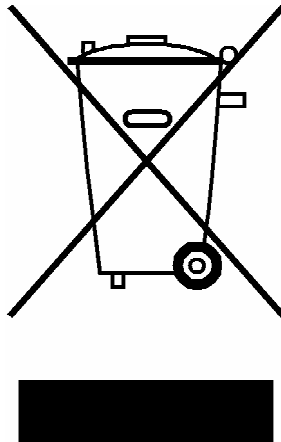

Product labeling in accordance with EN 50419

Once the lifetime of a product has ended, this product must not be disposed of in the standard domestic refuse. Even disposal via the municipal collection points for waste electrical and electronic equipment is not permitted.

Rohde & Schwarz GmbH & Co. KG has developed a disposal concept for the environmental-friendly disposal or recycling of waste material and fully assumes its obligation as a producer to take back and dispose of electrical and electronic waste in accordance with the ElektroG Act.

Please contact your local service representative to dispose of the product.



Qualitätszertifikat

Certificate of quality

Certificat de qualité

Certified Quality System
ISO 9001

Certified Environmental System
ISO 14001

Sehr geehrter Kunde,

Sie haben sich für den Kauf eines Rohde&Schwarz-Produktes entschieden. Hiermit erhalten Sie ein nach modernsten Fertigungsmethoden hergestelltes Produkt. Es wurde nach den Regeln unseres Qualitätsmanagementsystems entwickelt, gefertigt und geprüft. Das Rohde&Schwarz-Qualitätsmanagementsystem ist u.a. nach ISO9001 und ISO 14001 zertifiziert.

Der Umwelt verpflichtet

- ▮ Energie-effiziente, RoHS-konforme Produkte
- ▮ Kontinuierliche Weiterentwicklung nachhaltiger Umweltkonzepte
- ▮ ISO 14001-zertifiziertes Umweltmanagementsystem

Dear Customer,

You have decided to buy a Rohde&Schwarz product. You are thus assured of receiving a product that is manufactured using the most modern methods available. This product was developed, manufactured and tested in compliance with our quality management system standards. The Rohde&Schwarz quality management system is certified according to standards such as ISO9001 and ISO 14001.

Environmental commitment

- ▮ Energy-efficient products
- ▮ Continuous improvement in environmental sustainability
- ▮ ISO 14001-certified environmental management system

Cher client,

Vous avez choisi d'acheter un produit Rohde&Schwarz. Vous disposez donc d'un produit fabriqué d'après les méthodes les plus avancées. Le développement, la fabrication et les tests respectent nos normes de gestion qualité. Le système de gestion qualité de Rohde&Schwarz a été homologué, entre autres, conformément aux normes ISO9001 et ISO 14001.

Engagement écologique

- ▮ Produits à efficience énergétique
- ▮ Amélioration continue de la durabilité environnementale
- ▮ Système de gestion de l'environnement certifié selon ISO 14001

Customer Support

Technical support – where and when you need it

For quick, expert help with any Rohde & Schwarz equipment, contact one of our Customer Support Centers. A team of highly qualified engineers provides telephone support and will work with you to find a solution to your query on any aspect of the operation, programming or applications of Rohde & Schwarz equipment.

Up-to-date information and upgrades

To keep your instrument up-to-date and to be informed about new application notes related to your instrument, please send an e-mail to the Customer Support Center stating your instrument and your wish. We will take care that you will get the right information.

Europe, Africa, Middle East

Phone +49 89 4129 12345
customersupport@rohde-schwarz.com

North America

Phone 1-888-TEST-RSA (1-888-837-8772)
customer.support@rsa.rohde-schwarz.com

Latin America

Phone +1-410-910-7988
customersupport.la@rohde-schwarz.com

Asia/Pacific

Phone +65 65 13 04 88
customersupport.asia@rohde-schwarz.com





ROHDE & SCHWARZ

CE Declaration of Conformity



Certificate No.: 2011-09

This is to certify that:

Equipment type	Stock No.	Designation
FSMRxx	1313.9200.xx x = 1 to 9	MEASURING RECEIVER

complies with the provisions of the Directive of the Council of the European Union on the approximation of the laws of the Member States

- relating to electrical equipment for use within defined voltage limits (2006/95/EC)
- relating to electromagnetic compatibility (2004/108/EC)

Conformity is proven by compliance with the following standards:

EN 61010-1: 2001
EN 61326-1: 2006
EN 61326-2-1: 2006
EN 55011: 2007 + A2: 2007, Class B
EN 61000-3-2: 2006
EN 61000-3-3: 1995 + A1: 2001 + A2: 2005

For the assessment of electromagnetic compatibility, the limits of radio interference for Class B equipment as well as the immunity to interference for operation in industry have been used as a basis.

ROHDE & SCHWARZ GmbH & Co. KG
Mühldorfstr. 15, D-81671 München

Munich, 2011-03-16

Central Quality Management GF-QP / Chadzelek

1313.9200.xx

CE

E-1

Documentation Overview

The documentation of the R&S FSMR consists of base unit manuals and option manuals. All manuals are provided in PDF format on the CD-ROM delivered with the instrument. Each software option available for the instrument is described in a separate software manual.

The base unit documentation comprises the following manuals and documents:

- Quick Start Guide
- Operating Manual
- Service Manual
- Release Notes

Apart from the base unit, these manuals describe the models and options of the R&S FSMR Measuring Receiver that are listed in the documentation overview of the Operating Manual. All other options are described in separate manuals. These manuals are provided on the CD-ROM. For an overview of all options available for the R&S FSMR visit the R&S FSMR Measuring Receiver Internet site.

This manual is delivered with the instrument in printed form. It provides the information needed to set up and start working with the instrument. Basic operations and basic measurements are described. The function descriptions are provided in the Operating Manual. The Quick Start Guide includes general information (e.g. Safety Instructions) and the following chapters:

Quick Start Guide

- | | |
|-------------------|--|
| Chapter 1 | describes the control elements and connectors on the front and rear panel as well as all procedures required for putting the R&S FSMR into operation and integration into a test system. |
| Chapter 2 | gives an introduction to typical measurement tasks of the R&S FSMR which are explained step by step. |
| Chapter 3 | describes the operating principles, the structure of the graphical interface and offers a menu overview. |
| Chapter 10 | contains an index for the quick start guide. |

Contents - Chapter 1 " Preparing for Operation "

1 Preparing for Operation.....	1.1
Description of Front and Rear Panel Views.....	1.1
Front View	1.1
Rear View.....	1.11
Getting Started with the Instrument	1.16
Preparing the Instrument for Operation.....	1.16
Setting Up the Instrument.....	1.16
Standalone Operation	1.16
Safety Instruction for Instruments with Tilttable Feet	1.17
Rackmounting	1.17
EMC Safety Precautions	1.18
Connecting the Instrument to the AC Supply	1.18
Switching the Instrument On/Off	1.18
Switching On the Instrument.....	1.19
Startup Menu and Booting	1.19
Switching Off the R&S FSMR	1.19
Operating the R&S FSMR with the Removable Hard Disk Option R&S FSMR-B18 ...	1.19
Power-Save Mode.....	1.20
Recalling the Most Recent Instrument Settings	1.20
Function Test.....	1.20
Properties Specific to Windows XP	1.21
Connecting an External Keyboard.....	1.22
Connecting a Mouse	1.23
Connecting an External Monitor	1.24
Connecting a Printer	1.25
Selecting a Printer	1.25
Installation of Plug&Play Printers	1.28
Installation of Non-Plug&Play Printers.....	1.28
Local Printer	1.30
Configuring a Network Printer	1.34
Connection of USB Devices	1.36
Installing Windows XP Software.....	1.38
Windows XP Software Tested for the Instrument	1.38

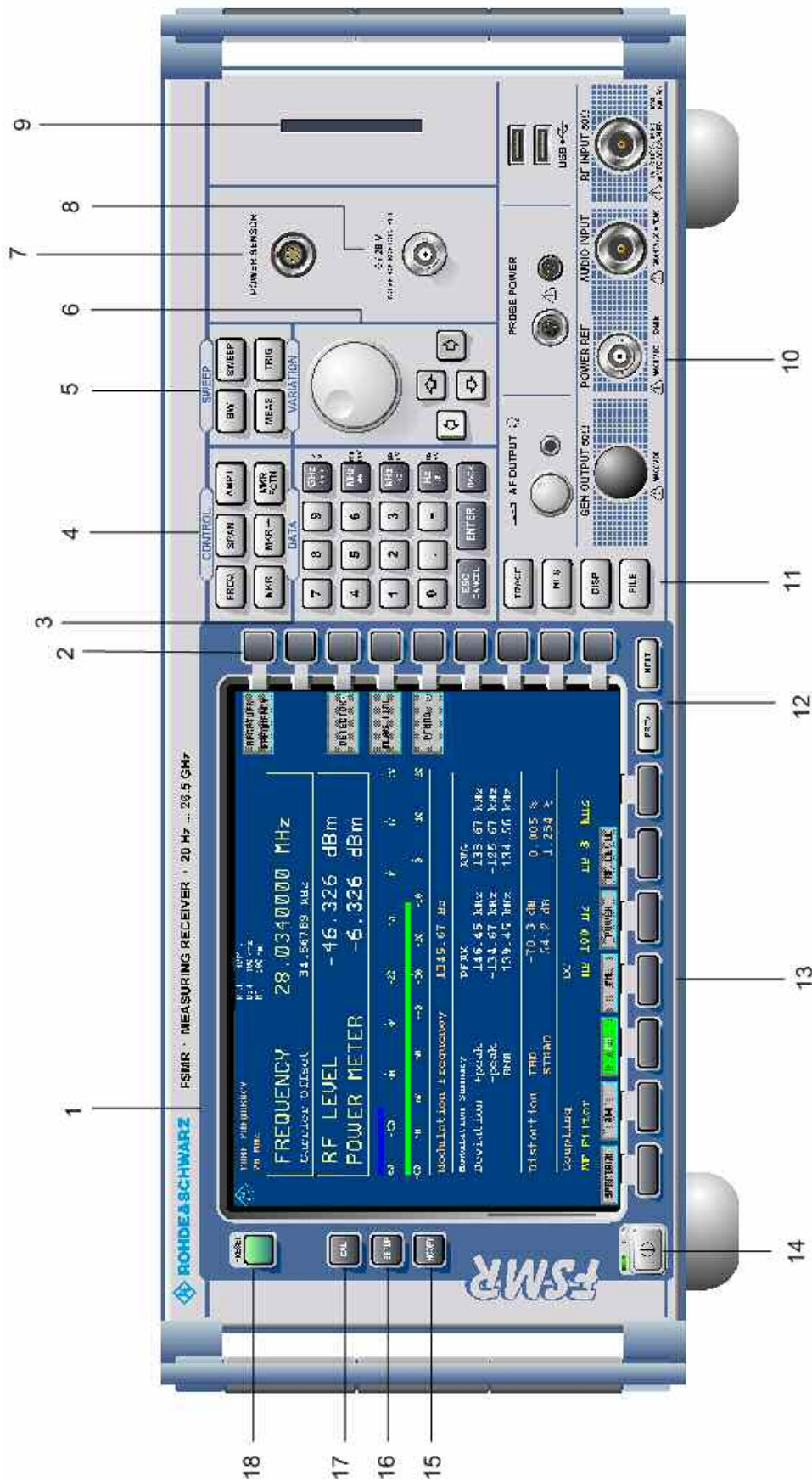

Fig. 1-1 Front View

1 Preparing for Operation

Chapter 1 describes the controls and connectors of the Spectrum Analyzer R&S FSMR by means of the front and rear view. Then follows all the information that is necessary to put the instrument into operation and connect it to the AC supply and to external devices.

A more detailed description of the hardware connectors and interfaces can be found in chapter 8. Chapter 2 provides an introduction into the operation of the R&S FSMR by means of typical examples of configuration and measurement; for the description of the concept for manual operation and an overview of menus refer to chapter 3.

For a systematic explanation of all menus, functions and parameters and background information refer to the reference part in chapter 4.

For remote control of the R&S FSMR refer to the general description of the SCPI commands, the instrument model, the status reporting system, and command description in chapter 5 and 6.

Description of Front and Rear Panel Views

Front View

1	Display Screen	see Chapter 3
2	Softkeys	see Chapter 3
3	 <p>Keypad for data input</p> <ul style="list-style-type: none"> 0...9 input numbers . input decimal point - change sign ESC – close input field (for uncompleted or already closed inputs, the original entry is kept) CANCEL – erase the current entry in input field (beginning of an input) – close message window (status, error and warning messages) ENTER close the data input. BACK – erase last character input for uncompleted input – restore previous input (undo) 	see Chapter 3

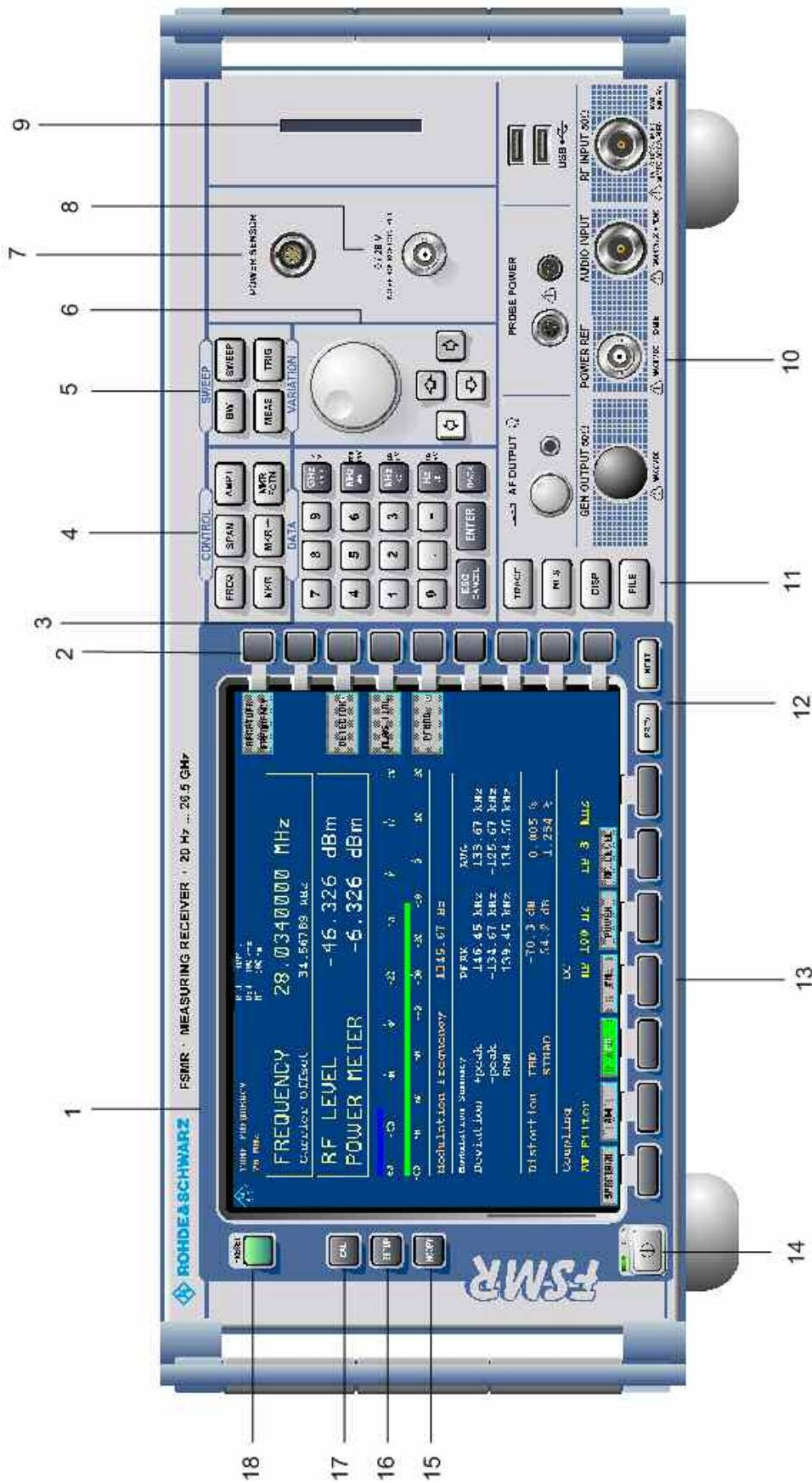

Fig. 1-1 Front View



Keypad for data input

GHz s
-dBm V

MHz ms
dBm mV

kHz μ s
dB μ V

Hz ns
dB.. nV

The units keys close the data input and define the multiplication factor for each basic unit. For dimension-less or alphanumeric inputs, the units keys have weight 1. They behave, in this case, like the ENTER key.

see Chapter 3

4



FREQ Set frequency axis

SPAN Set span

AMPT Set level indication and configure RF input.

MKR Select and set standard marker and delta marker functions.

MKR-> Change instrument settings via markers

MKR FCTN Select further marker and delta marker functions

see Chapter 4

5



BW – Set resolution bandwidth, video bandwidth and sweep time, – Set coupling of these parameters

SWEEP Select sweep

MEAS Select and set power measurements

TRIG Set trigger sources

see Chapter 4

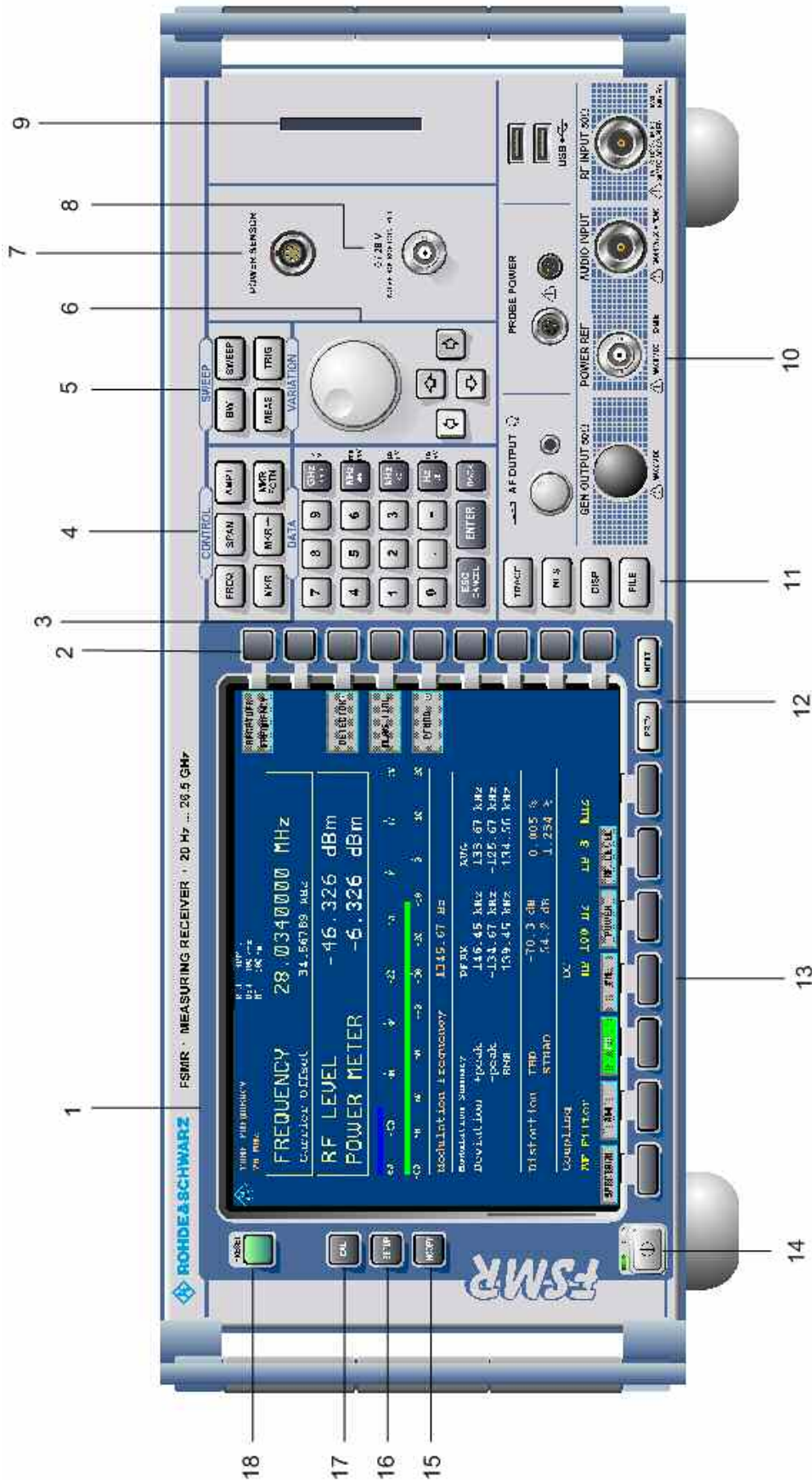
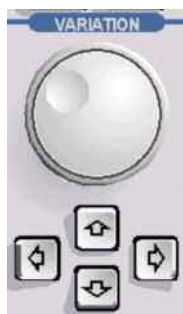

Fig. 1-1 Front View

6



- | | |
|---|----------------------|
| <p>Key group for entering data and for cursor movement</p> <p>Cursor keys</p> <ul style="list-style-type: none"> - Move the cursor within the input fields and tables. - Vary the input value. - Define the direction of movement for the roll-key. <p>Roll-key</p> <ul style="list-style-type: none"> - Vary input values. - Move markers and limits. - Select letters in the help line editor. - Move cursor in the tables - Close data input (ENTER) | <p>see Chapter 3</p> |
|---|----------------------|

7



Output connector for an external noise source

8



Connector for the power sensors NRP-Zx

s. Kap. 3

9

CF Card option R&S FSU-B18

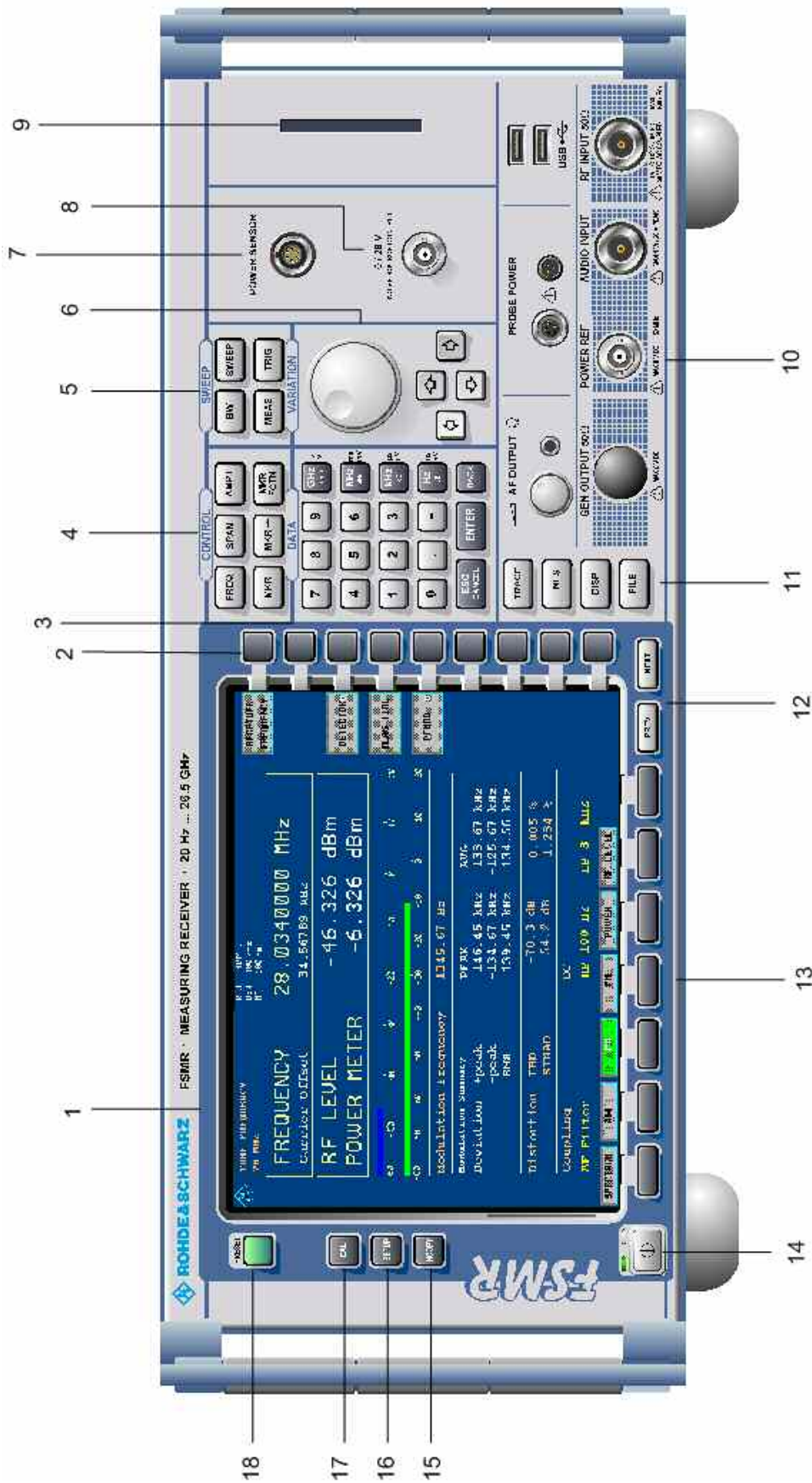







Fig. 1-1 Front View

10



AF OUTPUT		Volume control
		Head phone connector
PROBE POWER		Power supply and coded socket (+15 V/ -12 V) for accessories
USB		USB interfaces
RF INPUT		RF input
		Caution: The maximum DC voltage is 50 V, the maximum power is 1 W ($\hat{=} 30$ dBm) at ≥ 10 dB attenuation.
AUDIO INPUT		Audio input with 50 Ω or 1 M Ω input impedance
		Caution: The input can handle a maximum power of 1 W or a peak voltage of 20 V.
POWER REF		Reference source 50 MHz, 1mW
		Caution: The maximum DC voltage is 0.

s. Chapter 8

see Chapter 8

11



TRACE	Select and activate traces and detectors
LINES	Set limit lines
DISP	Configure display
FILE	– Save and recall instrument data – Configuration of memory media and data

see Chapter 4

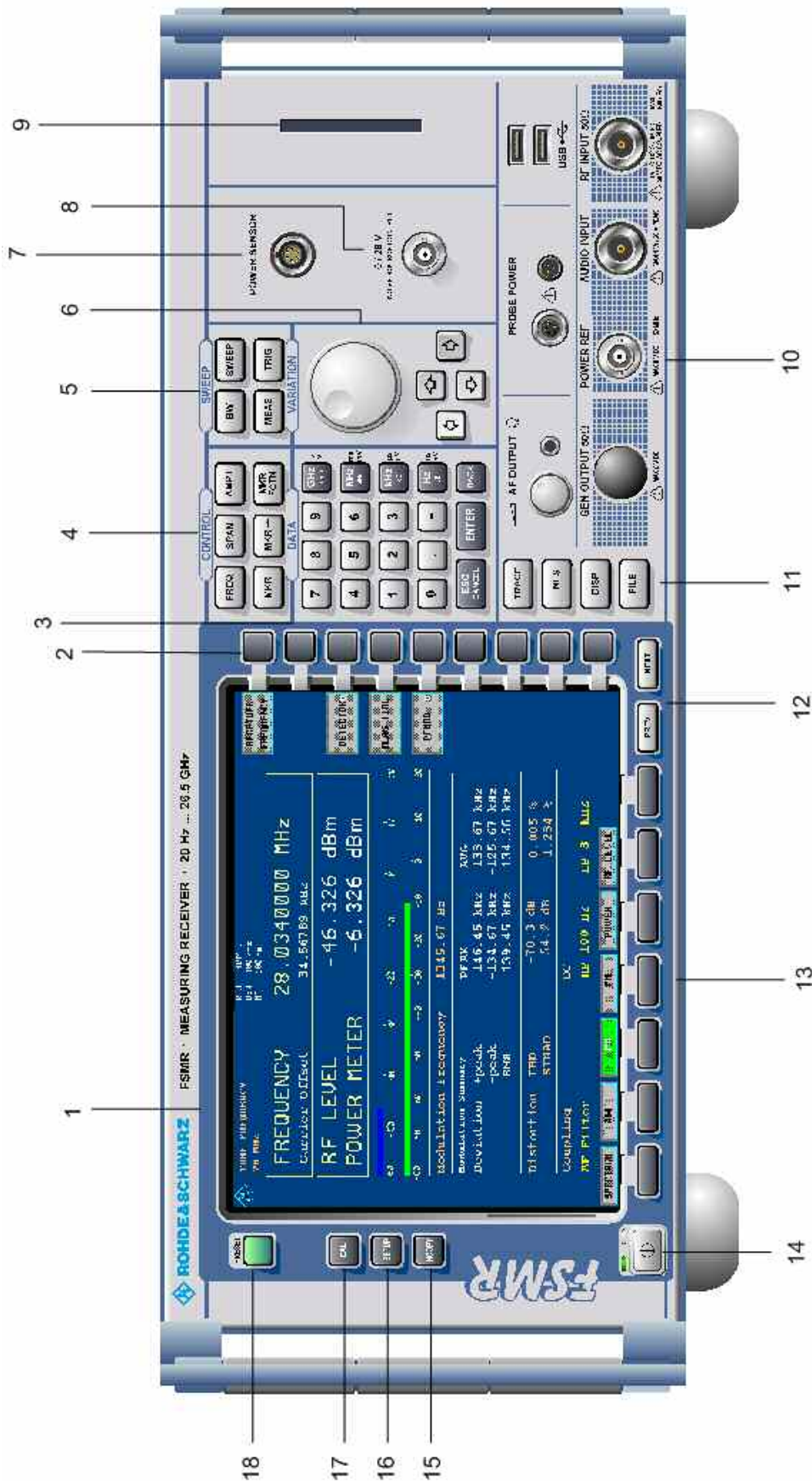



Fig. 1-1 Front View

12

	Menu-change keys	see Chapter 3
	NEXT Change to side menu	
	PREV Call main menu	

13

Hotkeys	see Chapter 3
---------	---------------

14

	ON/STANDBY switch	see Chapter 1
---	-------------------	---------------

15

	Configure and start a print job	see Chapters 1 and 4
--	---------------------------------	----------------------

16

	Define general configuration	see Chapter 4
---	------------------------------	---------------

17

	Record correction data	see Chapter 4
---	------------------------	---------------

18

	Call default settings	see Chapter 4
---	-----------------------	---------------

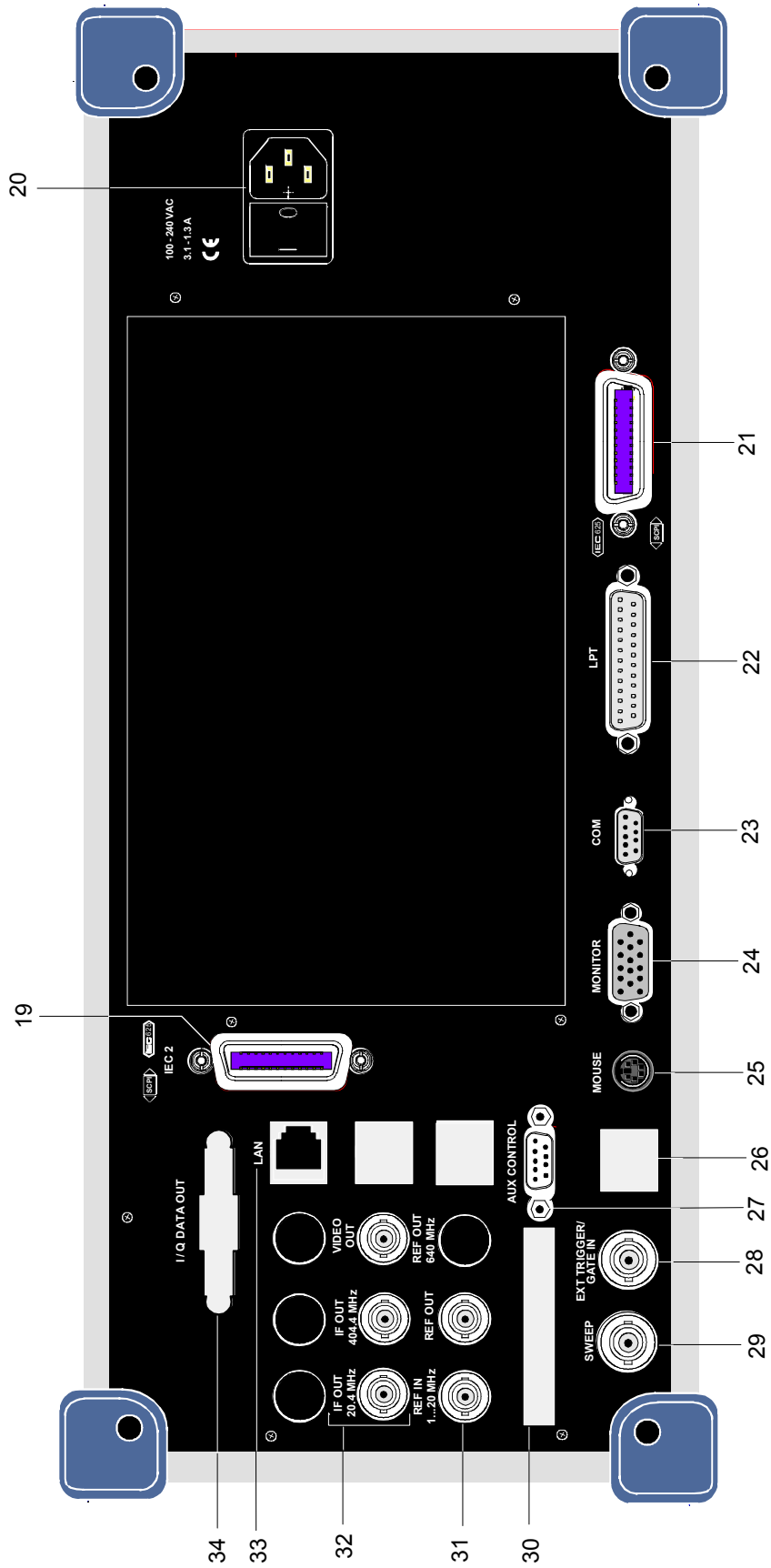

Fig. 1-2 Rear View

Rear View

19

2nd IEC/IEEE bus-connector

|| see Chapter 8

20

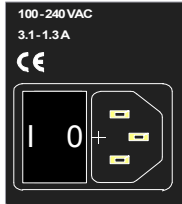

Power switch and AC power connector

|| see Chapter 1

21

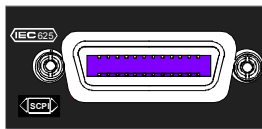

IEC/IEEE bus-connector

|| see Chapter 8

22

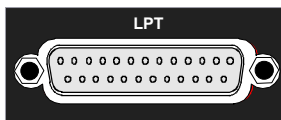

Parallel interface connector (printer connector)

|| see Chapter 8

23

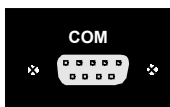

Connector for a serial interface (9-pin socket; COM)

|| see Chapter 8

24



Connector for an external monitor

|| see Chapter 8

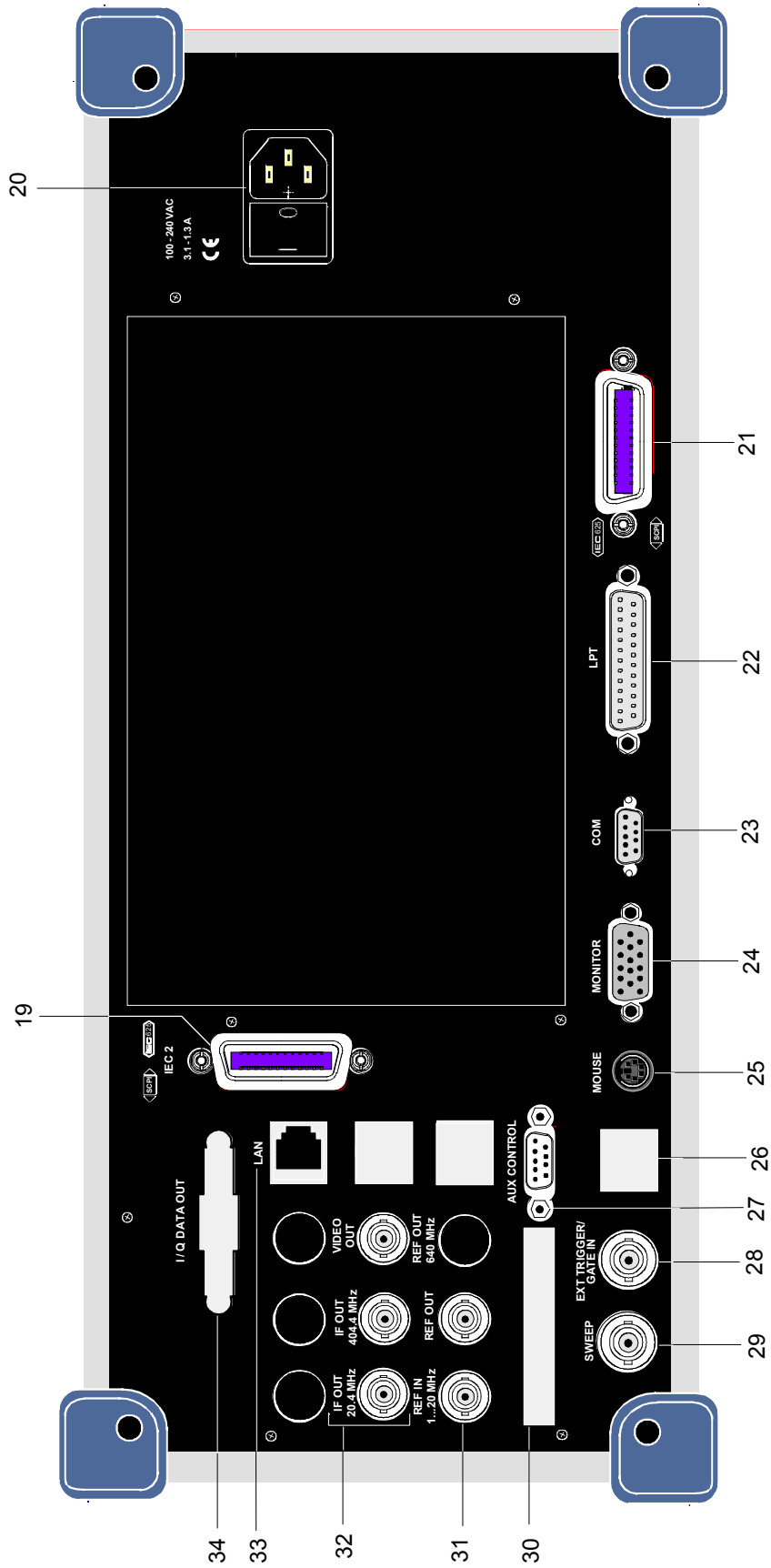

Fig. 1-2 Rear View

25



Connector for a PS/2 mouse

see Chapter 8

26



Connector for USB

see Chapter 8

27



Connector to control an external generator ((only with option FSP-B10)

28



Input connector for an external trigger or an external gate signal

see Chapter 8

29



Output connector
During a sweep sawtooth voltage is output which is proportional to frequency

s. Kap. 8

30

Reserved for options

31

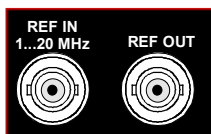

REF IN Input connector for an external reference (1 to 20 MHz)

REF OUT Output connector for an internal reference (10 MHz)

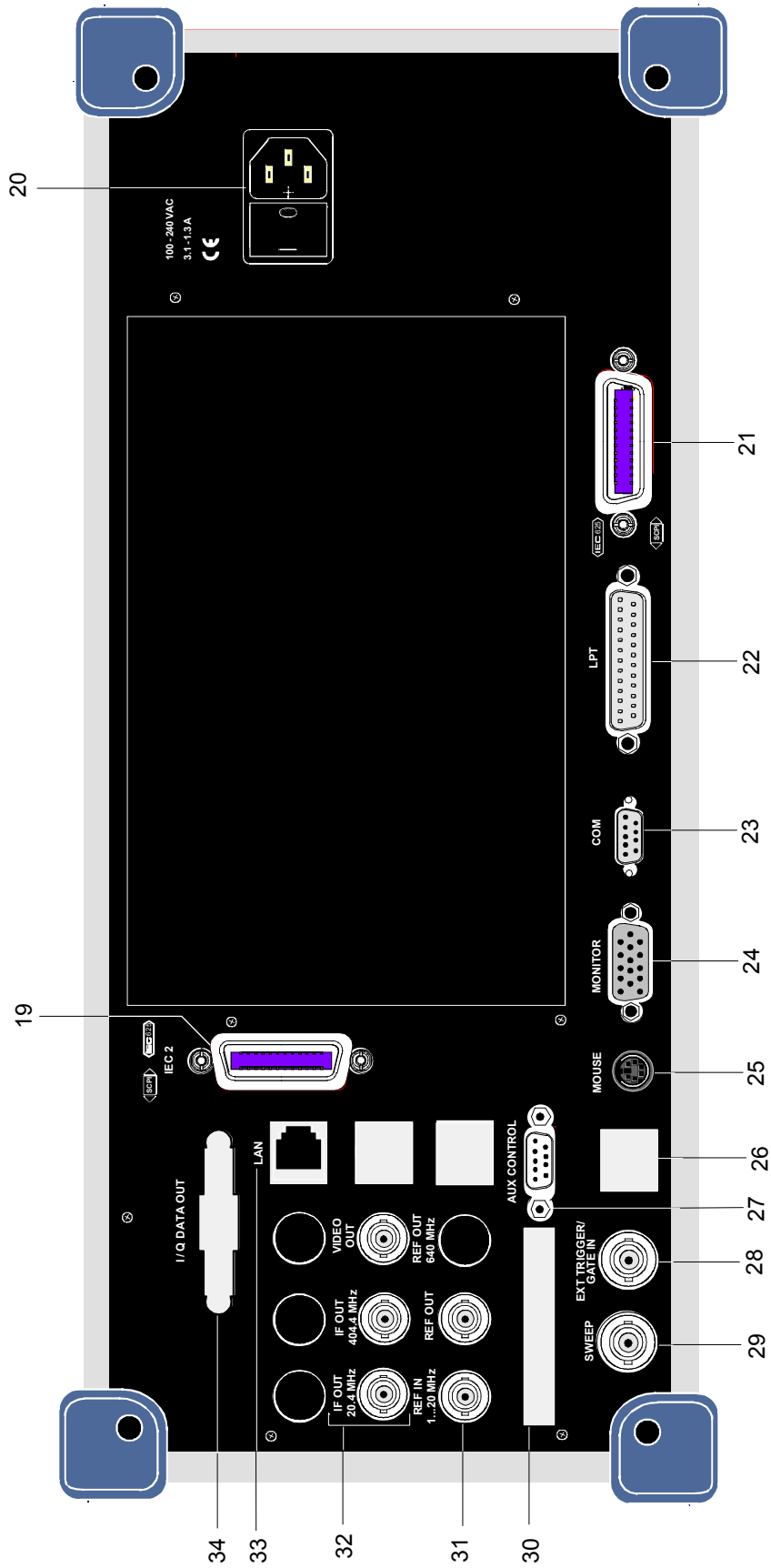
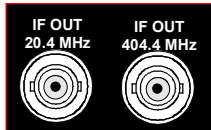

Fig. 1-2 Rear View

32



IF 20.4 MHz OUT Output connector for 20.4 MHz IF
 IF 404.4 MHz OUT Output connector for 404.4 MHz IF

see Chapter 8

33



LAN-Interface

34

Reserved for options

Getting Started with the Instrument

The following section describes how to activate the instrument and how to connect external devices such as printer and monitor.

Chapter 2 explains the operation of the instrument using simple measurement examples.

NOTICE

Optional notice heading

Prior to switching on the instrument, make sure that the following conditions are fulfilled:

- The instrument cover is in place and tightly screwed on
- Fan openings are not obstructed
- Signal levels at the inputs are within specified limits
- Signal outputs are connected correctly and not overloaded.

Any non-compliance may cause damage to the instrument

Preparing the Instrument for Operation

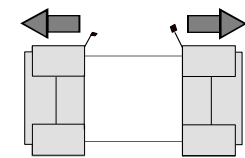

remove protective caps

- Take the instrument out of the packaging and check whether the items listed in the packing list and in the lists of accessories are all included.
- Remove the two protective covers from the front and rear of the R&S FSMR and carefully check the instrument for damage.
- Should the instrument be damaged, immediately notify the carrier and keep the box and packing material.
- For further transport or shipment of the R&S FSMR, the original packing should be used. It is recommended to keep at least the two protective covers of the front and rear panels in order to prevent damage to the controls and connectors.

Setting Up the Instrument

Standalone Operation

The instrument is designed for use under general laboratory conditions. The ambient conditions required at the site of operation are as follows:

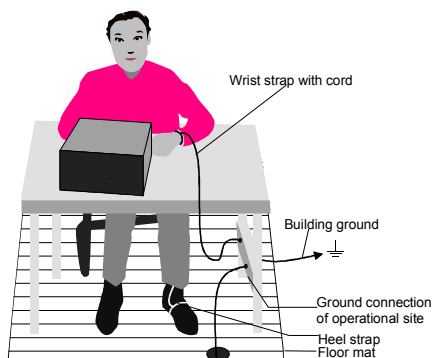

- The ambient temperature must be in the range specified in the data sheet.
- All fan openings must be unobstructed and the air flow at the rear panel and at the side-panel perforations must be unimpeded. The distance to the wall should be at least 10 cm.
- The mounting surface should be flat.
- To avoid damage of electronic components of the DUT due to electrostatic discharge on manual touch, protective measures against electrostatic discharge are recommended.

Safety Instruction for Instruments with Tiltable Feet

CAUTION

The feet must be fully folded in or out. Only in this way can the stability of the instrument be guaranteed and reliable operation be ensured. With the feet out, the total load for the feet must not exceed 500 N (own weight and additional units put onto the instrument). These units must be secured against slipping (e.g. by locking the feet of the unit at the top side of the enclosure).

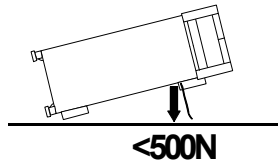

When shifting the instrument with the feet out, the feet might collapse and fold in. To avoid injuries, the instrument must therefore not be shifted with the feet out.

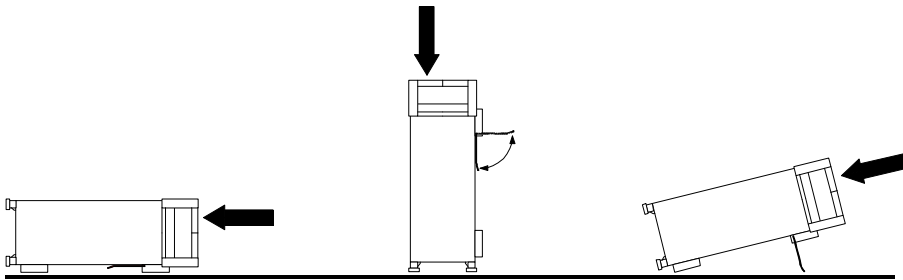

The instrument can be operated in any position.

Rackmounting

NOTICE

For rack installation, ensure that the air flow at the side-panel perforations and the air exhaust at the rear panel are not obstructed.

The instrument may be installed in a 19" rack by using a rack adapter kit (Order No. see data sheet). The installation instructions are part of the adapter kit.

EMC Safety Precautions

In order to avoid electromagnetic interference (EMI), the instrument may be operated only with all covers closed. Only adequately shielded signal and control cables may be used (see recommended accessories).

Connecting the Instrument to the AC Supply

The R&S FSMR is equipped with an AC voltage selection feature and will automatically adapt itself to the applied AC voltage (range: 100 to 240 V AC, 40 to 400 Hz). External voltage selection or adaptation of the fuses are not necessary. The AC power connector is located on the rear panel (see below).

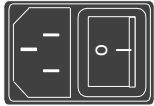

Power connector

- Connect the instrument to the AC power source using the AC power cable delivered with the instrument.

As the instrument is designed according to the regulations for safety class EN61010, it must be connected to a power outlet with earthing contact.

Switching the Instrument On/Off

NOTICE

Do not power down during booting.

Such a switch-off may lead to corruption of the hard disk files

AC power switch on the rear panel

Power switch Power connector

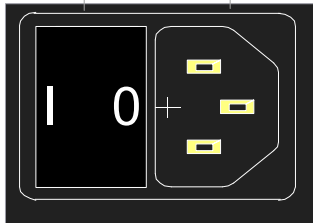

Power switch

Position I = ON

In the I position, the instrument is in standby mode or in operation, depending on the position of the ON/STANDBY key at the front of the instrument.

Note: *The AC power switch may remain ON continuously. Switching to OFF is only required when the instrument must be completely removed from the AC power source.*

Position O = OFF

The O position implies an all-pole disconnection of the instrument from the AC power source.

ON/STANDBY switch on the front panel

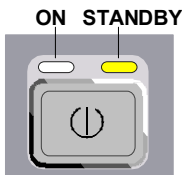

Standby switch

The ON/STANDBY switch activates two different operating modes indicated by coloured LEDs:

Operation ON - ON/STANDBY is depressed

The green LED (ON) is illuminated. The instrument is ready for operation. All modules within the instrument are supplied with power.

⚠ WARNING

Shock hazard

In standby mode, the AC power voltage is present within the instrument

STANDBY - ON/STANDBY switch is not pressed.

The yellow LED (STANDBY) is illuminated. Only the power supply is supplied with power and the quartz oven is maintained at normal operating temperature.

Switching On the Instrument

- In order to switch on the R&S FSMR, set the power switch on the rear panel to position I.
- Set the R&S FSMR to operating mode by pressing the *ON/STANDBY* key on the front panel. The green LED must be illuminated.

Startup Menu and Booting

After switching on the instrument, a message indicating the installed BIOS version (e.g. Analyzer BIOS Rev. 1.2) appears on the screen for a few seconds.

Subsequently Windows XP is booted first and after that the instrument firmware will boot. As soon as the boot process is finished the instrument will start measuring. The settings used will be the one that was active when the instrument was previously switched off, provided no other device configuration than *FACTORY* had been selected with *STARTUP RECALL* in the *FILE* menu.

Switching Off the R&S FSMR

- Switch the *ON/STANDBY* key on the front panel to standby mode by pressing it once.
The R&S FSMR will write the current instrument settings to disk before performing a Windows XP shutdown. At the end of the shutdown procedure the power supply will be switched to *STANDBY* mode.
The yellow LED must be illuminated.

Only when removing the R&S FSMR completely from the AC power source:

- Set the power switch at the rear panel to position 0.

Operating the R&S FSMR with the Removable Hard Disk Option R&S FSMR-B18

The R&S FSMR-B18 option allows the instrument to be operated with differently configured hard disks. Additional hard disks are therefore available as option FSU-B19.

⚠ CAUTION**Type and source of hazardous situation**

Switch off the instrument before you remove and exchange the hard disk. Exchanging the hard disk during operation can produce severe data errors.

Power-Save Mode

Display:

The R&S FSMR offers the possibility of switching on a power-save mode for the screen display. The backlighting will be switched off if no entry is made on the front panel (key, softkey or hotkey as well as spinwheel) during the selected response time.

In order to switch on the power-save mode:

1. Call the *DISPLAY - CONFIG DISPLAY* submenu to configure the screen display:
 - Press *DISP* key
 - Press *CONFIG DISPLAY* softkey
2. Activate the save mode
 - Press *DISPLAY PWR SAVE* softkey.
The softkey is highlighted in colour, thus indicating that the power-save mode is on. At the same time the data entry for the delay time is opened.
3. Define the delay time
 - Enter the required response time in minutes and confirm the entry using the *ENTER* key.
The screen will be blanked out after the selected time period has elapsed.

Hard disk:

A power-save mode is preset for the built-in hard disk which is automatically closed down 15 minutes after the last access.

Recalling the Most Recent Instrument Settings

The R&S FSMR stores its current instrument settings onto the hard disk every time it is switched off via the ON/STANDBY key. After each power-on, the R&S FSMR is reloaded with the operational parameters which were active just prior to the last power-off (STANDBY or AC power OFF) or were set with STARTUP RECALL (see Chapter 4 "Saving and Recalling Data Sets").



Storing the current instrument settings is not possible if the instrument is switched off using the POWER ON switch at the rear panel or when unplugging the mains cord. After power-on the instrument settings stored previously on the hard disk will be loaded in this case.

Function Test

After turning on the AC power, the R&S FSMR will display the following message on the display screen:

Rohde & Schwarz GmbH & Co. KG
Analyzer BIOS Vx.y

After appearance of the above message, a selftest of the controller hardware is performed. Subsequently, the Windows XP controller boots and the measurement screen will appear.

The system self-alignment is activated via *CAL* key, *CAL TOTAL* softkey. The individual results of the self-alignment (PASSED / FAILED) can be displayed in the *CAL* menu (*CAL RESULTS*). With the aid of the built-in selftest functions (*SETUP* key, *SERVICE*, *SELFTEST* soft keys), the functional integrity of the instrument can be verified and/or defective modules can be localized.

Properties Specific to Windows XP

The instrument contains the Windows XP operating system. To ensure that the instrument software functions properly, certain rules must be adhered to when using the operating system..

NOTICE

Possible impairment of the instrument function

The instrument is equipped with the Windows XP operating system. It is thus possible to install commercial off-the-shelf software on the instrument. The use and installation of commercial software may impair the instrument functions. We recommend that you only execute programs tested by Rohde & Schwarz with regard to their compatibility to the instrument software. The program packages that have been tested are listed in section Windows XP Software Tested for the Instrument.

Install only service packs approved by Rohde & Schwarz to avoid impairment of instrument functions that could lead to the necessity to repair the instrument.

The user is especially warned against using Service Packs of Windows XP Home or of the Professional Edition, since these Service Packs are not compatible with Windows XP Embedded.

The drivers and programs used on the instrument under Windows XP have been adapted to the instrument. Existing instrument software must only be modified with update software released by Rohde & Schwarz.

Login

Windows XP requires that users identify themselves by entering a user name and password in a login window. The instrument provides a factory-installed auto login function, i.e. login is carried out automatically in the background. The ID used for auto login has administrator rights. As user name and password *instrument* (lowercase) are set.

Administrator ID

The ID used by the instrument to perform auto login has administrator rights.

Windows XP Service Packs

The Windows XP operating system on the instrument is supplied with pre-installed XP service packs (SP1 and additional updates/fixes) that are necessary and suitable for operating the instrument.

Opening the Windows XP Start Menu

You can open the Windows XP Start menu by pressing the Windows key () or the key combination **CTRL+ESC**. From the start menu, you can navigate to the submenus by using the mouse or the arrow keys. To return to the measurement screen, activate the *R&S Analyzer Interface* button in the task bar.

You can also open the Windows Start menu with the *OPEN START MENU* softkey in the SETUP menu.

Connecting an External Keyboard

NOTICE

Connect the keyboard only when the instrument is switched off (STANDBY). Otherwise, proper functioning cannot be ensured due to interactions with the firmware.

The R&S FSMR allows an external PC keyboard to be connected to one of the USB interfaces on the front panel or on the rear panel.

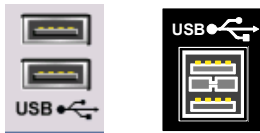

Keyboards and mouse devices conform to USB Standards 1.1 or 2.0 are suitable for connection to the USB interface.

Connecting a Mouse

To make Windows XP operation easier, the R&S FSMR allows a mouse to be connected to one of the USB interfaces interface on te front panel or on the rear panel.



Microsoft and Logitech mouse types are supported.



The recommended keyboard PSP-Z2 is equipped with a trackball for mouse control. Connecting an additional mouse will cause interface conflicts and lead to malfunctions of the instrument.

After connection the mouse is automatically recognized. Special settings such as mouse cursor speed etc, can be performed in the Windows XP menu START - SETTINGS - CONTROL PANEL - MOUSE. Chapter 8 contains the interface description for the connectors.

Connecting an External Monitor

NOTICE

The monitor may only be connected when the instrument is switched off (STANDBY). Otherwise, the monitor may be damaged.

Do not modify the screen driver (display type) and display configuration since this will severely affect instrument operation.

The instrument is equipped with a rear-panel MONITOR connector for the connection of an external monitor.

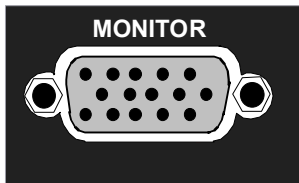

After connecting the external monitor the instrument needs to be rebooted in order to recognize the monitor. After that the measurement screen is displayed on both the external monitor and the instrument. Further settings are not necessary.

Connecting a Printer

A printer can be connected while the instrument is running.

The R&S FSMR allows two different printer configurations for printing a hardcopy to be created plus switchover between these two configurations. The *DEVICES* table in the *HCOPY* menu shows the available selection of installed printers (see section 4.4 "Documentation of Measurement Results").

The interfaces for connecting printers are on the rear panel:

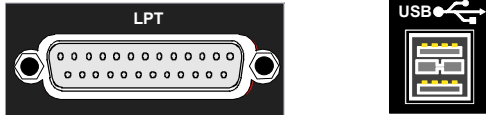

Chapter 8 contains the interface description for the connectors.

Selecting a Printer

Before a hardcopy can be printed, the printer has to be selected from the "*HCOPY*" menu.

In the following example, an HP DeskJet 660C printer that was preinstalled for LPT1 is selected as *DEVICE2* for hardcopies of the screen content.

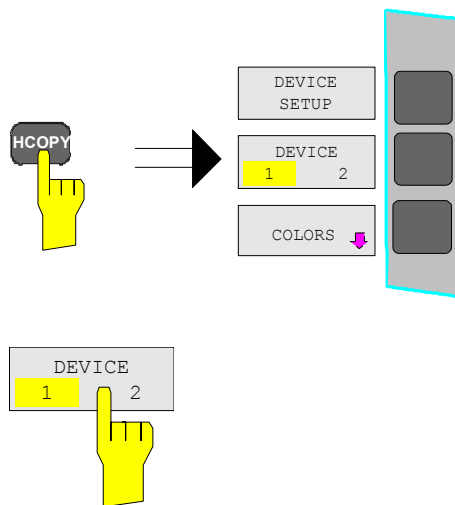

-
- Press the *HCOPY* key.
The *HCOPY* menu will open.

-
- Press the *DEVICE 1/2* softkey.
Device 2 will become the active output unit.

Note:
If the printer is to be operated as device 1, this step can be omitted.

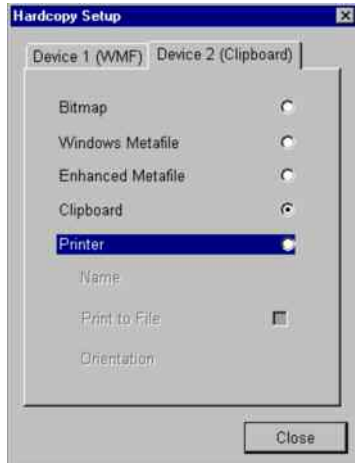
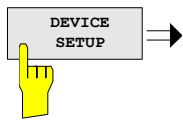

- Press the *DEVICE SETUP* softkey.

The *HARDCOPY SETUP* table opens and displays the selection of output formats. The current selection "*Clipboard*" is highlighted and marked with a dot in the option button.

- Use the cursor key to move the selection bar to "*Printer*" and press *ENTER*.

Windows for selecting a printer (Name), printing to file (Print to File) and selecting printout orientation (Orientation) are displayed.

- Use the cursor key to set the selection bar to "*Name*" and press *ENTER*.

The list of available printer types appears.

- Use the cursor key / or the spinwheel to move the selection bar to the "HP DeskJet 660C" printer and press *ENTER*.

The list closes and the selected printer appears in the "Name" field.

Note:

If the desired printer is not available in the selection list, its driver must first be installed.

For further information, see sections "Installation of Plug&Play Printers", "Installation of Non-Plug&Play Printers" and "Installation of Network Printers".

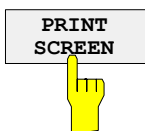



- Press the cursor key  or turn the spinwheel until the “Close” button is reached.

Further settings can still be made:

“Print to File” redirects printing to a file. In this case, the system prompts you for a file name when printing is started.

- The selection is activated by pressing *ENTER* or the spinwheel.

“Orientation” is used to switch between portrait and landscape format.

- To change the selection, open the list by pressing *ENTER* and select the desired orientation with the cursor key  / . To close the list, press *ENTER* again.

The “Close” button is used to complete the setup.

- Press *ENTER* as soon as the “Close” button is available.

The dialog closes. Printing will now be performed according to the selected settings.

Start printing

- Press the *PRINT SCREEN* softkey.

A hardcopy of the screen contents will be printed.

The factory setting for DEVICE 2 is “Clipboard”. In this case, the printout will be copied to the Windows XP clipboard which is supported by most Windows applications. The contents of the clipboard can be pasted directly into a document via EDIT – PASTE.

Table 1-1 shows the factory settings for the two output devices.

Table 1-1 Factory settings for *DEVICE 1* and *DEVICE 2* in the *HCOPY* menu

Setting	Selection in configuration table	Setting for <i>DEVICE 1</i>	Setting for <i>DEVICE 2</i>
Output device	DEVICE	WINDOWS METAFILE	CLIPBOARD
Output	PRINT TO FILE	YES	---
Orientation	ORIENTATION	---	---

Installation of Plug&Play Printers

The installation of Plug&Play printers under Windows XP is quite simple: After the printer is connected and switched on, Windows XP automatically recognizes it and installs its driver, provided the driver is included in the XP installation. If the XP printer driver is not found, Windows XP prompts you to enter the path for the corresponding installation files. In addition to pre-installed drivers, a number of other printer drivers can be found in directory D:\I386.



When you install printer drivers that are not pre-installed on the instrument, the installation process will prompt you to specify the path containing the new driver. This can be a memory stick or USB CD-ROM drive (see section “Connection of USB Devices”).

Installation of Non-Plug&Play Printers



The dialogs below can be controlled either from the front panel or via the mouse and keyboard (see sections “Connecting a Mouse” and “Connecting a Keyboard”). Mouse and PC keyboard are absolutely essential for configuring network printers.

A new printer is installed with the *INSTALL PRINTER* softkey in the *HCOPY* menu.

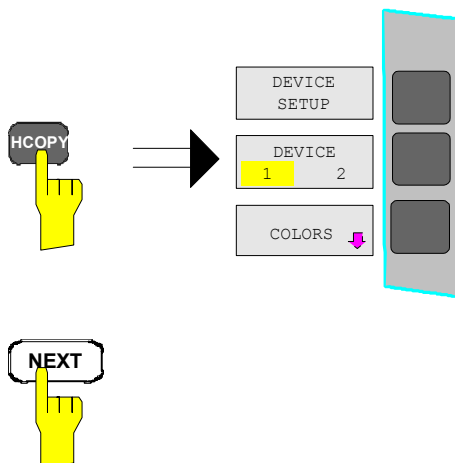

- Press the *HCOPY* key.
The *HCOPY* menu will open.

- Press the *NEXT* key to open the side menu.

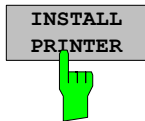

- Press *INSTALL PRINTER* to open the *Printers and Faxes* dialog window.

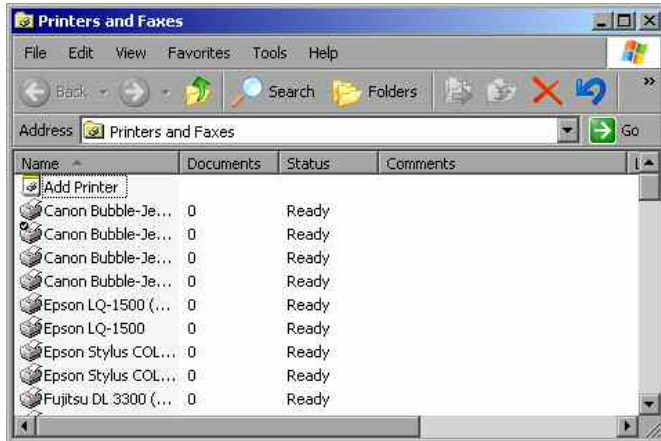

- Select *Add Printer* in the list using the spinwheel.
 - Highlight the selected item with *CURSOR RIGHT* and press *ENTER* or the spinwheel to confirm the selection.
- The *Add Printer Wizard* is displayed.



- Select *NEXT* with the spinwheel and press the spinwheel for confirmation.
- Local or Network Printer* can be selected.



- To install a local printer, select *Local printer attached to this computer* with the spinwheel. Press the spinwheel for confirmation and continue with the "Local Printer" section.
- To install a network printer, select *A network printer, or a printer attached to another computer*. Press the spinwheel for confirmation and continue with the "Network Printer" section.

Local Printer

In the following example, a Star LC24 printer is connected to the LPT1 interface and configured as *DEVICE2* for hardcopies of screen contents. The Add Printer Wizard has already been opened as described in the section “Starting the Add Printer Wizard”.

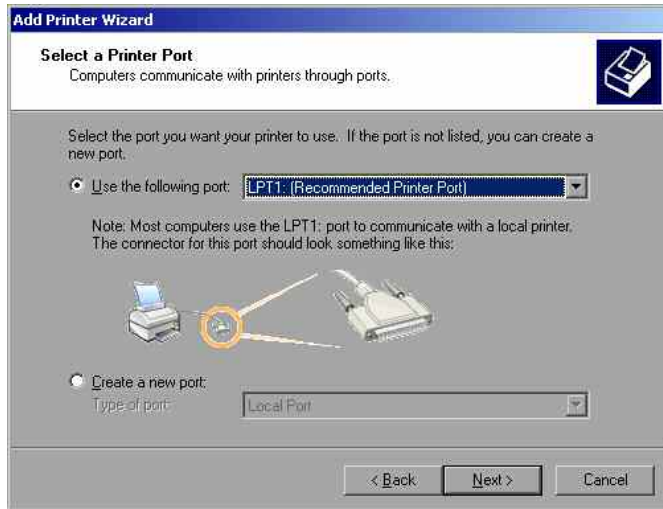

- To select the USB interface, open the list of ports by clicking the spinwheel. Select the printer port with spinwheel/arrow keys and confirm by pressing the spinwheel. The selection list is closed again.
- To select the LPT connector, the selection list need not be opened.
- Place the cursor on the *Next* button and confirm by pressing the spinwheel. The “Install Printer Software” dialog is opened.



- Select the desired manufacturer (“Star”) in the Manufacturer table using the up / down keys.



- Go to the *Printers* list with the spinwheel.
- Select the desired printer type (Star LC24-200 Colour) using the up / down keys and confirm with *ENTER*.

Note:
 If the desired printer type is not in the list, the respective driver is not installed yet. In this case click the *HAVE DISK* button with the mouse key. You will be prompted to insert a disk with the corresponding printer driver. Press *OK* and select the desired printer driver.

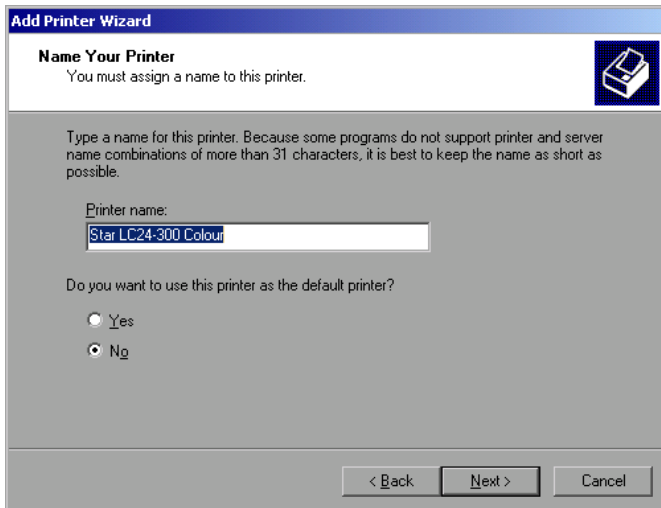

- The printer name can be changed as required in the *Printer name* entry field (max. 60 characters). A PC keyboard is required in this case.
- Use the spinwheel to select *Yes* or *No* for the default printer.
- Choose the desired status with the up /down keys.
- Confirm with *ENTER*.

The *Printer Sharing* dialog is opened.

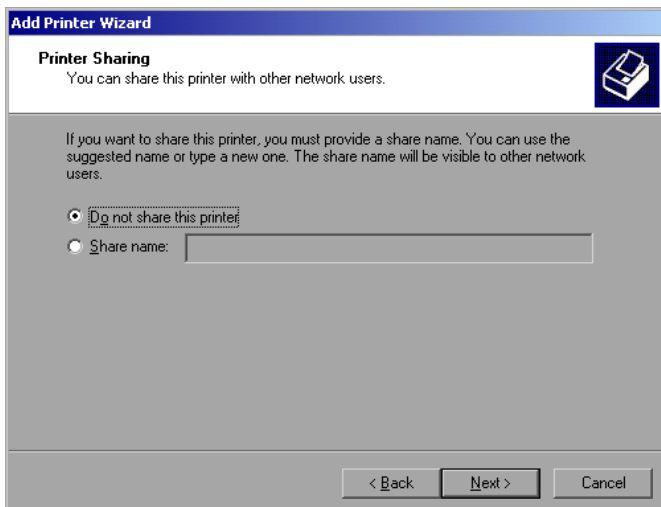

- Exit the dialog with *ENTER*.
- The *Print Test Page* dialog is opened.

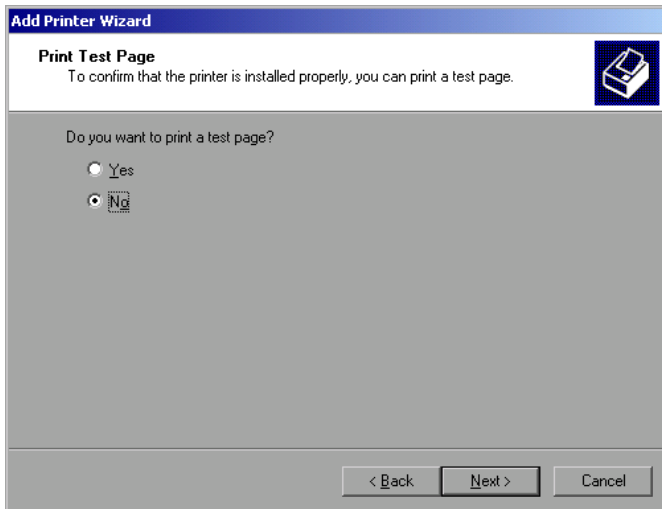

- Exit the dialog with *ENTER*.

The *Completing the Add Printer Wizard* dialog is opened.

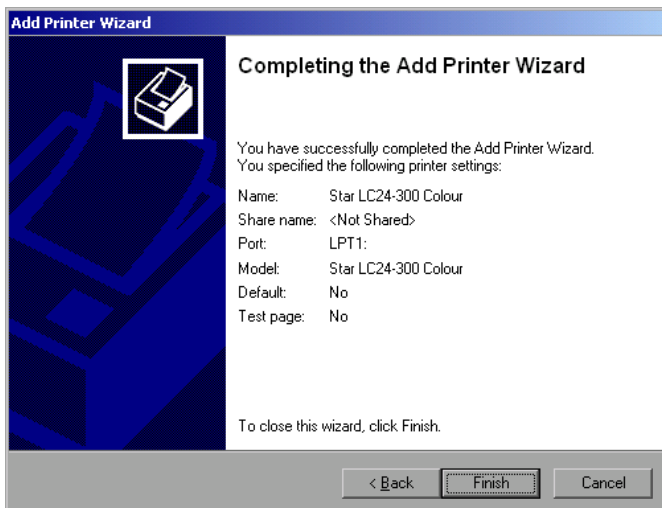

- Check the displayed settings and exit the dialog with *ENTER*.

The printer is installed. If Windows finds the required driver files, the installation is completed without any further queries.

If Windows cannot find the required driver files, a dialog is opened where the path for the files can be entered.

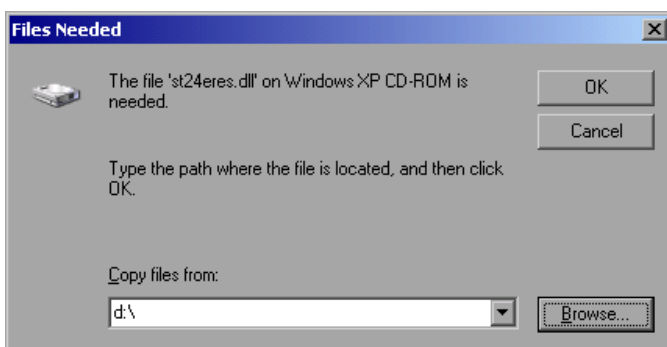

- Select the *Browse* button with the spinwheel and confirm with by pressing the spinwheel.

The *Locate File* dialog is opened.



- Turn the spinwheel to select the directory and path D:\I386 and press it to confirm the selection.

If the selected item is not printed on a blue background, it must be marked with the cursor up / down keys before it can be activated by pressing the spinwheel.

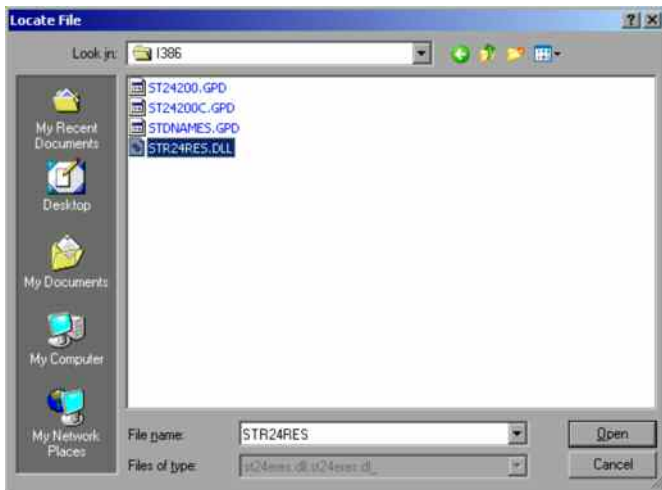

- Select the driver file with the spinwheel and confirm by pressing the spinwheel.

The file is included in the *Files Needed* dialog.

Note:

If the desired file is not in the D:\I386 directory, a disk with the driver file is needed. In this case, exit the dialog with ESC and repeat the selection starting from the "Files needed" dialog.

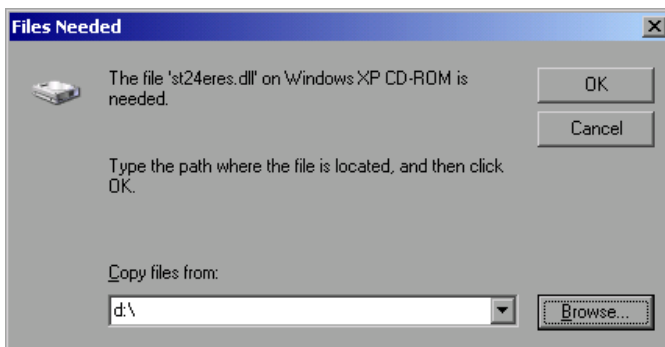

- Select the OK button with the spinwheel and press the spinwheel to confirm.

The installation is completed.

Finally, the instrument must be configured for printout with this printer using the softkeys *DEVICE SETUP* and *DEVICE 1/2* in the hardcopy main menu (see section "Selecting a printer").

Configuring a Network Printer

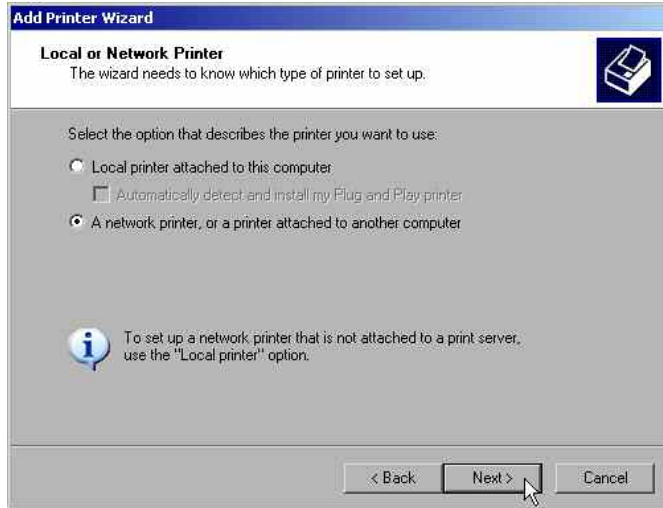

➤ To select a network printer, click the option "A network printer or a printer attached to another computer".

Continue with *Next*.

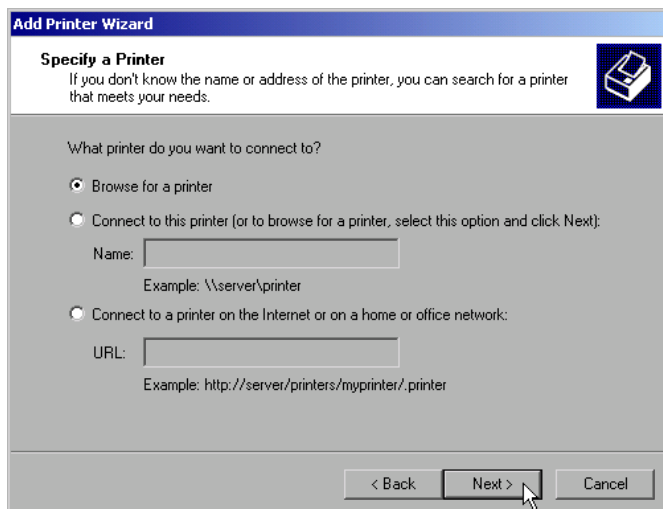

➤ Click *Browse for a printer* and then *Next*.

A list of selectable printers is displayed.

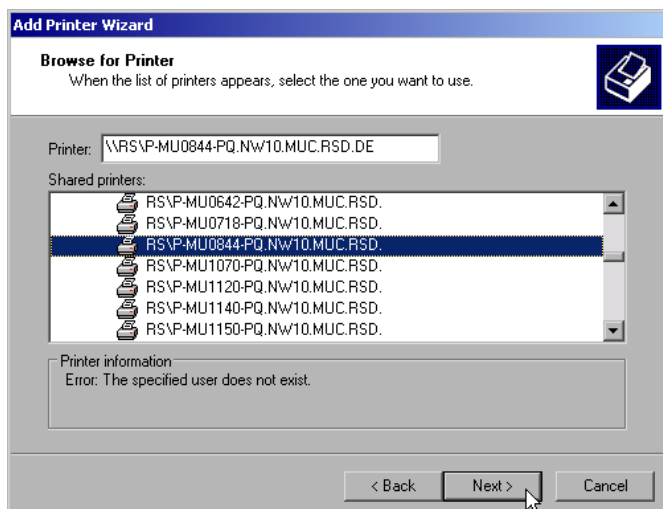

➤ Mark the desired printer and select it with *OK*.

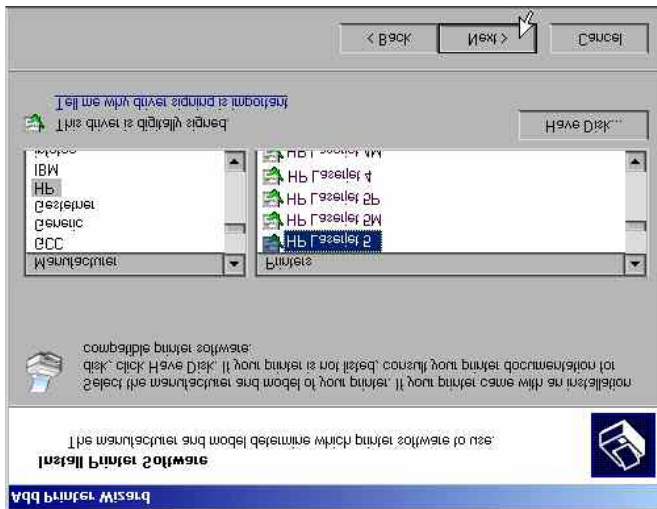

- Confirm the subsequent prompt to install a suitable printer driver with "OK". The list of available printer drivers is displayed. The manufacturers are listed in the left-hand table, the available printer drivers in the right-hand table.
- Select the manufacturer from the *Manufacturers* table and then the printer driver from the *Printers* table.

Note:

If the desired type of output device is not shown in the list, the driver has not yet been installed. In this case, click the "HAVE DISK" button. You will be prompted to insert a disk with the corresponding printer driver. Insert the disk, select "OK" and then choose the desired printer driver.

- Click *Next*.

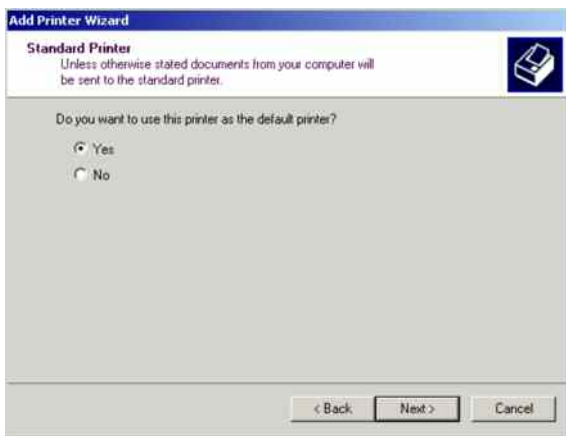

If one or more printers have already been installed, this window queries whether the printer last installed is to be used as the default printer for the Windows XP applications. The default selection is *No*.



- Start the printer driver installation with *Finish*.

Finally, the instrument has to be configured for printout with this printer using the softkeys *DEVICE SETUP* and *DEVICE 1/2* in the hardcopy menu (see section "Selection of a Printer").

Connection of USB Devices

Up to two USB devices can be directly connected to the analyzer via the USB interface on the rear of the R&S FSMR. This number can be increased as required by interconnecting USB hubs. Owing to the wide variety of available USB devices, the R&S FSMR can be expanded with almost no limitations. The following list shows a selection of USB devices suitable for the R&S FSMR:

- Power Sensor R&S NRP-Z11 or R&S NRP-Z21 (Adapter Cable R&S NRP-Z4 required)
- Pendrive (memory stick) for easy data transfer from/to the PC (e.g. firmware updates)
- CD-ROM drive for easy installation of firmware applications
- PC keyboard for entering comments, file names, etc
- Mouse for easy operation of Windows dialogs
- Printer for documentation of measurement results
- Modem for remote control of the R&S FSMR over great distances

The installation of USB devices is quite simple under Windows XP since all USB devices are Plug&Play. Apart from the keyboard and the mouse, all USB devices can be connected to or disconnected from the R&S FSMR while the instrument is running.

After the instrument is connected to the USB interface, Windows XP automatically searches for a suitable device driver.

If Windows XP does not find a suitable driver, you will be prompted to specify a directory where the driver software can be found. If the driver software is on a CD, a USB CD-ROM should first be connected to drive to the R&S FSMR.

As soon as the connection between the R&S FSMR and the USB device is interrupted, Windows XP will again recognize the modified hardware configuration and will deactivate the corresponding device driver.

Example:

Connecting a pendrive (memory stick) to the R&S FSMR:

1. After the pendrive is connected to the USB interface, Windows XP will recognize the newly connected hardware:



2. Windows XP installs the corresponding driver. After successful installation, XP signals that the unit is ready for operation:

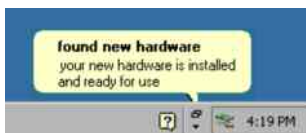

3. The pendrive is now available as a new drive and is displayed in Windows Explorer:

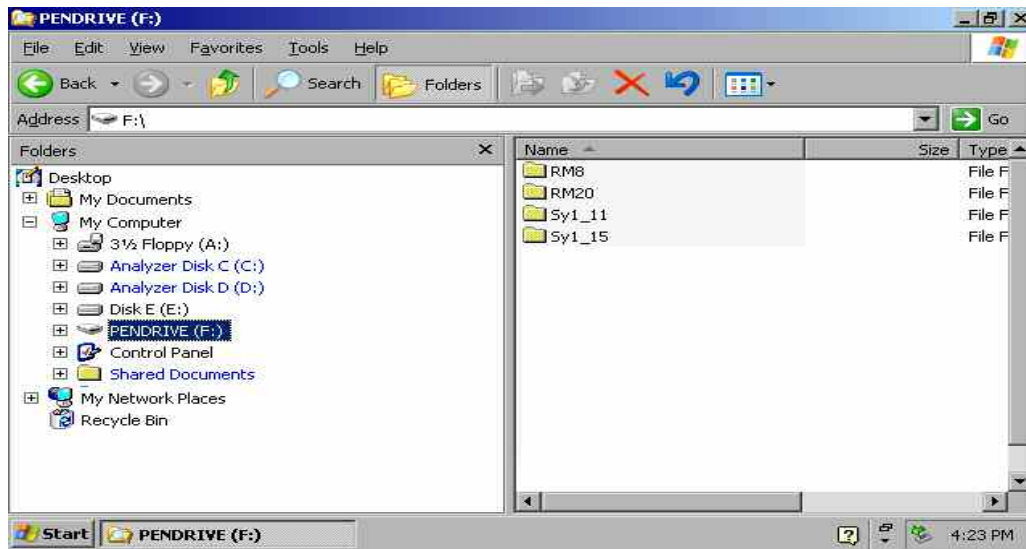

The pendrive can be used as a normal drive to load or save files.

4. If the pendrive is no longer required or if files are to be transferred to another computer, the pendrive is simply disconnected. Windows XP will then deactivate the driver. If the corresponding drive is still selected in Explorer, an error message will be displayed indicating that the drive is no longer available.

Installing Windows XP Software

Windows XP Software Tested for the Instrument

The driver software that is used and the system settings of Windows XP have been fine-tuned to support the measurement functions of the R&S FSUP. Thus, flawless instrument function is ensured only if software and hardware tested or offered by Rohde & Schwarz are used.

Using other software or hardware may cause the functions of the R&S FSMR to perform improperly or fail.

The following program packages have been successfully tested for compatibility with the measurement instrument software:

- R&S FS-K3 – Software for measuring noise factor and gain
- R&S FS-K4 – Software for measuring phase noise
- R&S Power Viewer (virtual power meter for displaying results of the power sensors of the R&S NRP-Zxx series)
- Windows XP Remote Desktop
- FileShredder – For reliable deletion of files on the hard disk
- Symantec Norton AntiVirus – Virus-protection software
- McAfee Virusscan

Contents – Chapter 2 "Getting Started"

1 Getting Started	2.1
Instrument overview	2.1
Setup the instruments.....	2.1
Select the Preset state	2.2
Measurement Examples.....	2.3
Example 1: RF Power Measurements with a Power Sensor	2.4
Measurement	2.4
Main Receiver Functions.....	2.4
Measurement Setup.....	2.4
Measurement Sequence – RF Power Measurements	2.4
Example 2: Low RF Level Measurements with Tuned RF Level Mode	2.7
Measurement	2.7
Main Receiver Functions.....	2.7
Measurement Setup.....	2.7
Measurement Sequence – Tuned RF Level Measurements	2.7
Example 3: AM Modulation and Modulation Distortion Measurements.....	2.13
Measurement	2.13
Main Receiver Functions.....	2.13
Measurement Setup.....	2.13
Measurement Sequence – AM Modulation Measurements	2.13
Example 4: Audio Measurements with the Audio Analyzer mode.....	2.17
Measurement	2.17
Main Receiver Functions.....	2.17
Measurement Setup.....	2.17
Measurement Sequence – Audio Measurements	2.17

2 Getting Started

This chapter provides a fast introduction to operation by guiding the user step by step through measurement examples .

Before starting any measurement with the FSMR, please note the instructions given in chapter 1 of the users manual for putting the instrument into operation. In chapter 3 you will find detailed information on customizing the instrument and the display.

For a systematic explanation of all menus, functions and parameters and background information refer to the reference part in chapter 4.

Instrument overview

The R&S FSMR is a very versatile instrument that combines many measurement capabilities required for calibration, troubleshoot and development into a single box instrument. The following functions are included:

- **RF Power Meter**, for highest accuracy RF power measurement.
- **RF Level Meter**, for measurements of low level signals.
- **Modulation Analyzer**, for AM/FM and ϕ M modulated signals.
- **Audio Analyzer**, for Audio Signal level and distortion, using the Audio input.
- **Frequency Counter**, fastest frequency measurements with „mHz“-resolution.
- **Spectrum Analyzer**, for high performance spectral analysis capabilities.

The R&S FSMR still offers an easy-to-use operation which does not require expert knowledge to perform the basic measurements.

This product note is designed to explain the functions and operation of the Measuring Receiver R&S FSMR. In the following descriptions, each step is explained in detail so that the instrument can be immediately used without the need for learning all of the available functions.

Setup the instruments

Most of the following examples use the same test setup. To perform the measurements, in addition to the Measuring Receiver R&S FSMR a signal generator and a power sensor is required. The examples in this paper will require a single, stable RF test signal at lower RF frequencies (for example 100 MHz). The generator shall offer analog modulation capabilities (at least AM modulation) at a variable modulation rate from 1 kHz to 3 kHz and 30 % modulation depth.

For the audio measurement examples a LF generator is required. Most of the R&S signal generators are equipped with a modulation generator which is sufficient for these measurements (for example R&S SML, R&S SMIQ).

The power sensor used in the examples shall be one of the sensors from the R&S NRP series. There are many different sensors available, a terminating average power sensor will best fit to the requirements (for example R&S NRP-Z21)

Select the Preset state

All of the following examples assume the standard settings for the measuring receiver. These are set with the *PRESET* key. The *PRESET* must be set to Factory default values and measuring Receiver Mode.

Check the *PRESET* setting with the following steps:



SETUP



NEXT



PRESET
RECEIVER



FILE



STARTUP
RECALL

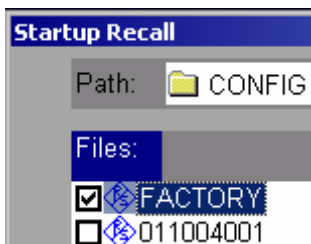

PRESET

1. Define Preset instrument mode

- Press the *SETUP* key.
The setup menu is opened.
- Press the menu change key *NEXT*.
The submenu is opened.
- Press the *PRESET RECEIVER* softkey.
The following presets will force the instrument into the Measuring Receiver mode.

2. Define the Startup Recall

- Press the *FILE* key.
The file menu is displayed.
- In the *FILE* menu press the *STARTUP RECALL* softkey.

A table with available instrument recall states is displayed.

- In the *STARTUP* table, highlight the entry named "FACTORY" and enable it with the *Enter* key as *STARTUP RECALL*.

3. Reset the instrument.

- Press the *PRESET* key.
The main receiver menu is opened. The receiver mode is set.
-

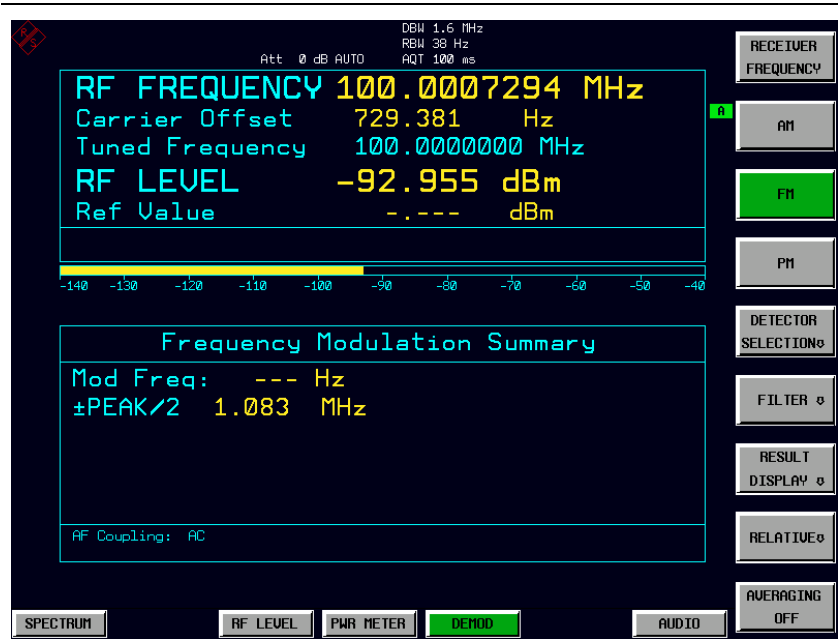

Fig.2-1 Display after selecting the default setup in receiver mode

The main default parameters are listed in the following table:

Table 2-1 Default parameters after preset in measuring receiver mode

Parameter	Parameter Name	Value
Receiver frequency	Frequency	100 MHz
Reference Level	Ref Level	Manual -20 dBm
RF attenuation	RF ATT	Auto
Preamplifier	Preamp	Off
Demodulation	Demod	FM
Detector	Det.	+/- peak/2
Measurement time	Meas Time	100 ms
Trigger	Trigger	Free run

Measurement Examples

All of the following examples assume the standard settings for the measuring receiver. These are set with the *PRESET* key

The described measurement applications are:

- Measurement of the RF power of a signal using the Power Meter mode.
- Measurement of low level signals using the Tuned RF Level mode.
- Measurement of AM modulated signals and modulation distortion with the Modulation Analyzer mode.
- Measurement of audio signals with the Audio Analyzer mode.

Example 1: RF Power Measurements with a Power Sensor

Measurement

The FSMR includes a power meter functionality. Measurements of RF Power will be performed in the power meter mode with highest accuracy. The FSMR will automatically handle all required correction factors and compensate the measurements. The FSMR does support the following Rohde&Schwarz power sensors:

- R&S NRP-Z11 10 MHz to 8 GHz / 200 pW to 200 mW
- R&S NRP-Z21 10 MHz to 18 GHz / 200 pW to 200 mW
- R&S NRP-Z51 DC to 18 GHz / 1 uW to 100 mW
- R&S NRP-Z55 DC to 40 GHz / 1 uW to 100 mW

Main Receiver Functions

The power meter functions are available in the Measuring Receiver *POWER METER*-mode. All required settings and evaluations can be reached from the *POWER METER* main menu.

Measurement Setup



Fig.2-2 RF Power measurement setup

The following settings are used on the generator:

1. *PRESET* the generator.
2. Set RF Frequency to 1 GHz.
3. Set the output level to 0 dBm.

Measurement Sequence – RF Power Measurements

Connect the Power sensor with the Signal Generator output and with the Measuring Receiver power sensor connector on the front panel.

The following steps are performed:

1. Zero the power sensor.
2. Connect the power sensor to the DUT.
3. Set the RF frequency.
4. Measure the RF Power

1. Zero the Power Sensor



- **Reset the instrument.**
- Press the *PRESET* key.

The main receiver menu is opened. The receiver mode is set.

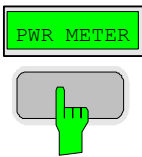

Switching to Power Meter Mode

- Press the *PWR METER* hotkey.

The power meter menu is displayed.



Set the measuring frequency

- Press the *FREQ* key on the front panel.
- In the frequency menu press the *RECEIVER FREQUENCY* softkey.

The measuring receiver frequency menu is displayed.

The frequency entry is displayed. Enter the measuring frequency with the number keys and the appropriate unit key. The frequency will be used by the instrument to calculate the calibration factors for the power sensor head.

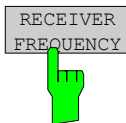

- In the *RECEIVER FREQUENCY* entry window key in "1000 MHZ".

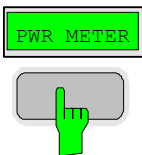

Zero the power sensor

- Press the *PWR METER* hotkey.

The power meter menu is displayed.

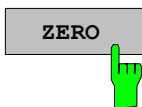

- In the *POWER METER* menu press the *ZERO* softkey.

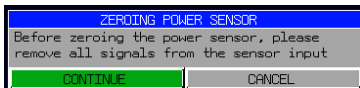

- In the message box, confirm *CONTINUE* and press *ENTER*.

The zeroing of the sensor will be performed.

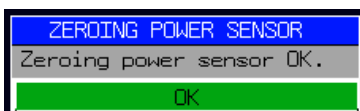

After the zeroing is completed, a message will appear on the screen.

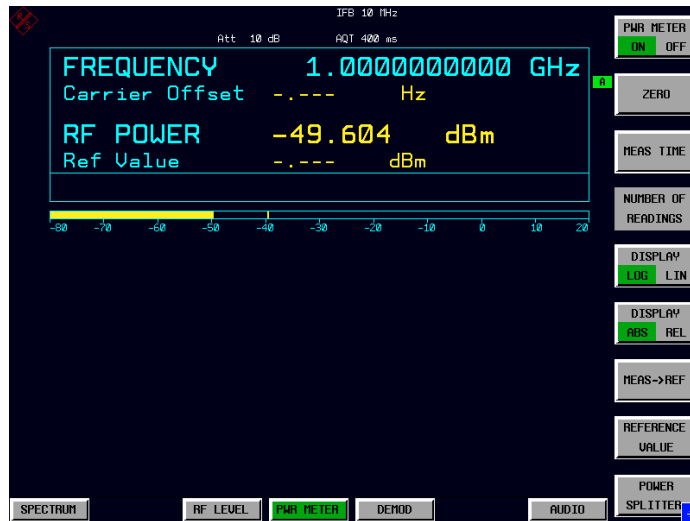
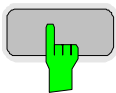

Fig.2-3 RF power measurement after Zeroing



PWR METER



DISPLAY LOG LIN



2. Measure the RF power in Watt

Connect the power sensor to the signal generator RF output

Linear display – Change the Unit to Watt

- Press the *PWR METER* hotkey.
The POWER METER menu is displayed.
- In the POWER METER menu press the *DISPLAY LOG / LIN* softkey.

The RF power unit is changed from dB to Watt.



Fig.2-4 RF power measurement in UNIT Watt

Example 2: Low RF Level Measurements with Tuned RF Level Mode

Measurement

The main functionality of a measuring receiver is the RF level measurement. Measurements of low power RF signals will be performed in the Tuned RF Level mode with highest accuracy. The FSMR will automatically handle all required settings.

Main Receiver Functions

The measurement of RF levels over a wide input level range is performed in three different level ranges. To reach the highest possible accuracy, a calibration is performed with a power sensor. The FSMR does offer fully automated calibration procedures in the Tuned RF Level mode. The following example will guide through the calibration steps. All functions for Tuned RF level measurements can be reached from the RF LEVEL main menu.

Measurement Setup

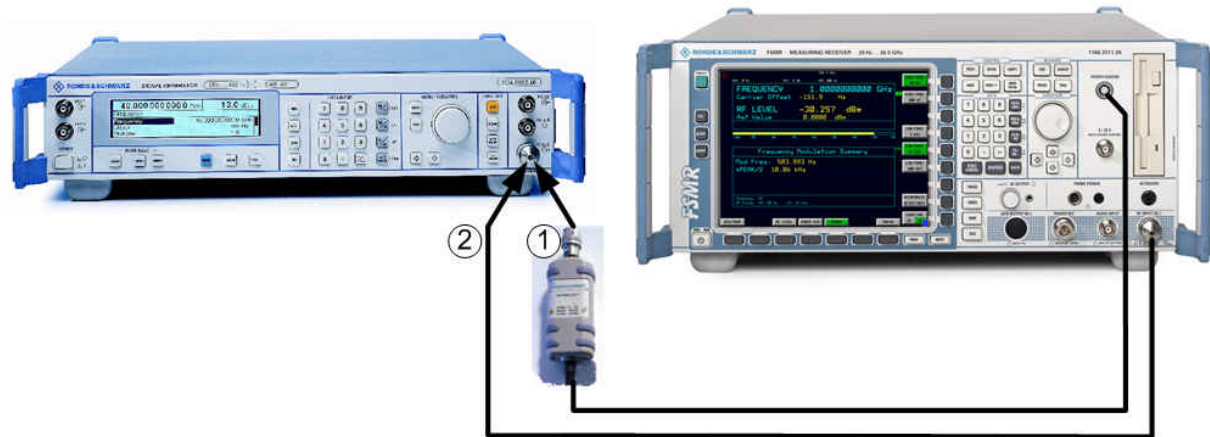

Fig.2-5 Tuned RF Level measurement setup

The following settings are used on the generator:

1. *PRESET* the generator.
2. Set RF Frequency to 300 MHz.
3. Set the output level to 0 dBm.

Measurement Sequence – Tuned RF Level Measurements

Connect the Power sensor with the Signal Generator output and with the Measuring Receiver power sensor connector on the front panel.

The following steps are performed:

1. Calibrate the FSMR with the power meter.
2. Change the output level and perform further Range calibrations.
3. Average the results for enhanced stability.
4. Measure an unstable source (unstable frequency)

1. Calibrate the setup- absolute power calibration



- **Reset the instrument.**
- Press the *PRESET* key.

The main receiver menu is opened. The receiver mode is set.

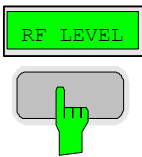

Switching to Tuned RF Level Mode

- Press the *RF LEVEL* hotkey.

The Tuned RF level menu is displayed.



Set the measuring frequency

- Press the *FREQ* key on the front panel.
- In the frequency menu press the *RECEIVER FREQUENCY* softkey.

The measuring receiver frequency menu is displayed.

The frequency entry is displayed. Enter the measuring frequency with the number keys and the appropriate unit key.

- In the *RECEIVER FREQUENCY* entry window key in "300 MHZ".



Connect the power sensor to the signal generator RF output

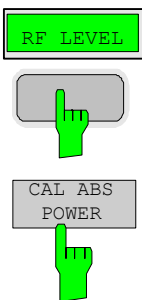

Calibrate the Tuned RF Level – Absolute Power calibration

- Press the *RF LEVEL* hotkey.
- In the *RF LEVEL* menu press the *CAL ABS POWER* softkey.

The *RF LEVEL* menu is displayed.

The calibration of the receiver will be performed. A message box with instructions about the setup appears. The first step is a power measurement with the power sensor connected to the source.

- In the message box, confirm *CONTINUE* and press *ENTER*.

In the next step of the calibration the receiver is connected to the source.

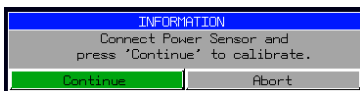

- **Connect FSMR RF input to the signal generator RF output**

- In the next message box, confirm *CONTINUE* and press *ENTER*.

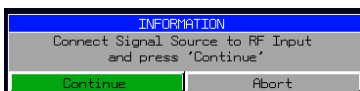

The FSMR is now calibrated in one RF level range (the upper level range does handle RF levels from -10 dBm to +30 dBm). Measurements in this level range can now performed with full accuracy.

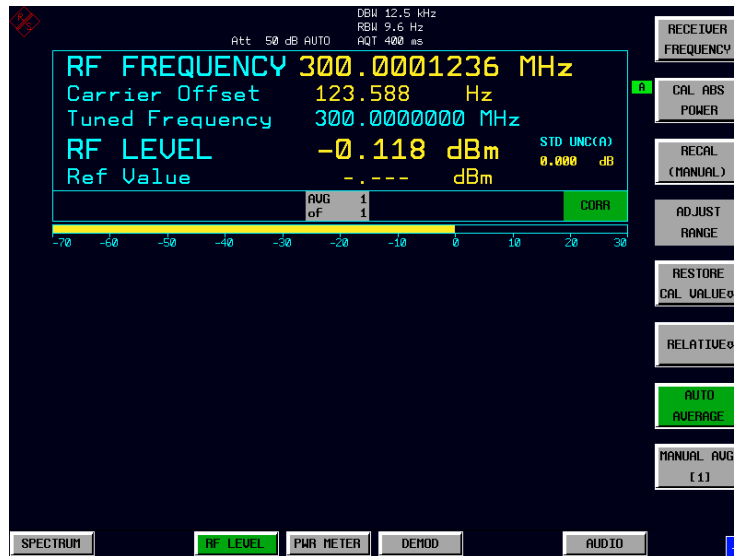
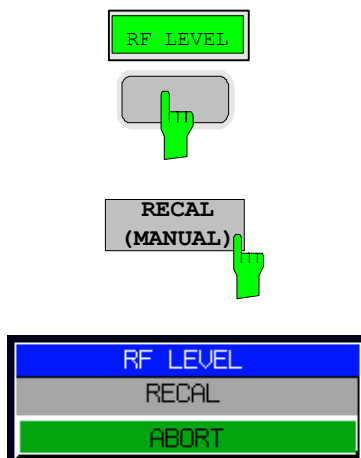

Fig.2-6 Tuned RF Level measurement after calibration

2. Range to range calibration- relative calibration

Change the signal generator output level

- The following settings are used on the generator:
Change the signal generator RF Level in 1 dB steps down. Observe the FSMR screen for the yellow RECAL message to appear (at levels about -10 dBm). This is the point where the automated Range-to-Range calibration can be performed.



The FSMR is now ready for a RF level range change. The calibration of the level difference due to the range change will be performed.

- Press the *RF LEVEL* hotkey.
The RF LEVEL menu is displayed.
- In the RF LEVEL menu press the *RECAL (MANUAL)* softkey.

The RECAL procedure is performed. Do not change any signal generator settings at this time.

A message box appears. The instrument will perform a measurement in the calibrated range, then change the RF settings (RF attenuator, IF gain) and then measure again. After the recalibration measurements with high accuracy are available in the RF level range 2 (covers levels from -10 dBm to -50 dBm).



RF LEVEL

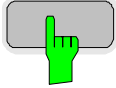

RECAL
(MANUAL)



Change the signal generator output level further down

- The following settings are used on the generator:
Change the signal generator RF Level in 10 dB steps down. Observe the FSMR screen for the yellow RECAL message to re-appear again (at levels about -50 dBm).

As soon as the RECAL flag appears, the FSMR is ready for a next RF level range change. The calibration of the level difference due to the range change will be performed.

- Press the RF LEVEL hotkey.
The RF LEVEL menu is displayed.
- In the RF LEVEL menu press the *RECAL (MANUAL)* softkey.
The RECAL procedure is performed.

A message box appears. The instrument will perform a measurement in the calibrated range, then change the RF settings (RF attenuator, IF gain) and then measure again. After the recalibration measurements with high accuracy are available in the RF level range 3 (covers levels from -50 dBm to noise level).

The FSMR is now calibrated in all RF level ranges (for RF levels from -140 dBm to +30 dBm). Measurements in all level ranges can now be performed with full accuracy. No further calibration is required, the Autorange function will automatically adapt the level setting of the FSMR to the input signal.



Fig.2-7 Tuned RF Level measurement at low levels

3. Average the results for enhanced stability



Change the signal generator output level further down

- The following settings are used on the generator:
Change the signal generator RF Level to -110 dBm).

The FSMR is now performing a calibrated measurement at – 110 dBm. The reading will be flickering due to a low signal to noise ratio. For a more stable reading, the FSMR does offer several functions.

The stability of a low level measurement is mainly depending on the measurement time. A longer acquisition of the signal does allow for a more accurate measurement. The averaging of several single acquisitions will lead to an effective longer measurement time.

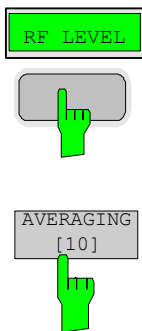

- Press the RF LEVEL hotkey.

The RF LEVEL menu is displayed.

- In the RF LEVEL menu press the *MANUAL AVG* softkey.

The AVERAGE will be switched on. The number of measurements can be entered in the AVERAGING COUNT box which appears on top of the screen. The default value is set to 10 Averages.

The instrument will now perform an averaged measurement. The average function is a floating average over the number of measurements chosen with the Average Count entry (default value: 10).



Fig.2-8 Tuned RF Level measurement with Averaging



4. Measure an unstable source (unstable in frequency)

The simulation of unstable sources requires a signal which is unstable in the frequency domain. This signal can be simulated with active frequency modulation on the signal generator.

- The following settings are used on the generator:
 1. *PRESET* the generator.
 2. Set RF Frequency to 100 MHz.
 3. Set the output level to 0 dBm.
 4. Select FM Modulation, 3 kHz deviation.
 5. Set the Modulation frequency to 1 kHz.



- Reset the instrument.
- Press the PRESET key.
The main receiver menu is opened. The receiver mode is set.

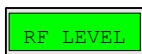

Switching to Tuned RF Level Mode

- Press the RF LEVEL hotkey.
The Tuned RF level menu is displayed.
Set the measuring frequency

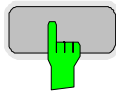

- In the RF LEVEL menu press the RECEIVER FREQUENCY softkey.

The frequency entry is displayed. Enter the measuring frequency with the number keys and the appropriate unit key.

- In the RECEIVER FREQUENCY entry window key in "100 MHZ".

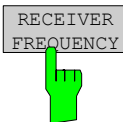

The measurement of an unstable signal requires the measuring receiver to use a wide bandwidth. The FSMR offers a wideband detector mode to acquire wideband signals with high accuracy

- In the RF LEVEL menu press the DETECTOR WIDE softkey.

The wideband detector mode acquire signals with the full acquisition bandwidth. The acquisition bandwidth (DEMODO BW) of the FSMR can be set in the BW menu, the preset value is 12.5 kHz. The bandwidth must be set wide enough to capture the maximum frequency deviation of the input signal. In this example, the frequency deviation is set to 3 kHz and the default bandwidth is 12.5 kHz.

Note: The wideband detection is not only suitable for unstable signals, it can also be used to accurately measure modulated signals

Next steps:

The following steps will be performed as described in the previous example (Tuned RF Level).

Example 3: AM Modulation and Modulation Distortion Measurements

Measurement

The FSMR includes a modulation analyzer. Measurements like AM, FM or PM modulation will be performed in the modulation analyzer mode. The instrument offers standard measurements like modulation depth, deviation and modulation frequency, but also more sophisticated function like modulation distortion or audio frequency response are available.

Main Receiver Functions

The modulation analyzer functions are available in the Measuring Receiver *DEMOD*-mode. All required settings and evaluations can be reached from the DEMOD main menu.

Measurement Setup



Fig.2-9 AM modulation measurement setup

The following settings are used on the generator:

1. *PRESET* the generator.
2. Set RF Frequency to 100 MHz.
3. Set the output level to - 30 dBm.
4. Select the AM Modulation, 30% modulation depth.
5. Set the Modulation frequency to 1 kHz.

Measurement Sequence – AM Modulation Measurements

Connect the Signal Generator output with the Measuring Receiver RF Input.

The following measurement steps are performed:

1. Measure the AM modulation depth.
2. Relative Audio measurements
3. Measure the Total harmonic distortion in %.

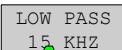
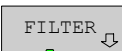
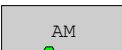
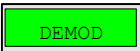

1. Measure the AM modulation depth

- **Reset the instrument.**
- *Press the PRESET key.*

The main receiver menu is opened. The receiver mode is set.

Switching to AM demodulation

- *Press the DEMOD hotkey.*
- *The analog demodulation menu is displayed.*
- *In the DEMOD menu press the AM softkey.*

The modulation frequency and the AM modulation depth with peak detection measurement results are displayed in the lower window of the screen. The upper window shows the RF Frequency and the RF input level.

Limiting the bandwidth - Audio Filters

- Press the *DEMOD* hotkey.
- The analog demodulation menu is displayed.
- In the DEMOD menu press the *FILTER* softkey.

The audio filter menu is displayed. To suppress unwanted broadband noise or harmonics of the demodulated signal, the bandwidth of the measurement can be limited with highpass and lowpass filters.

- In the FILTER menu press the *LOW PASS 15 KHZ* softkey.

The following screen is displayed:

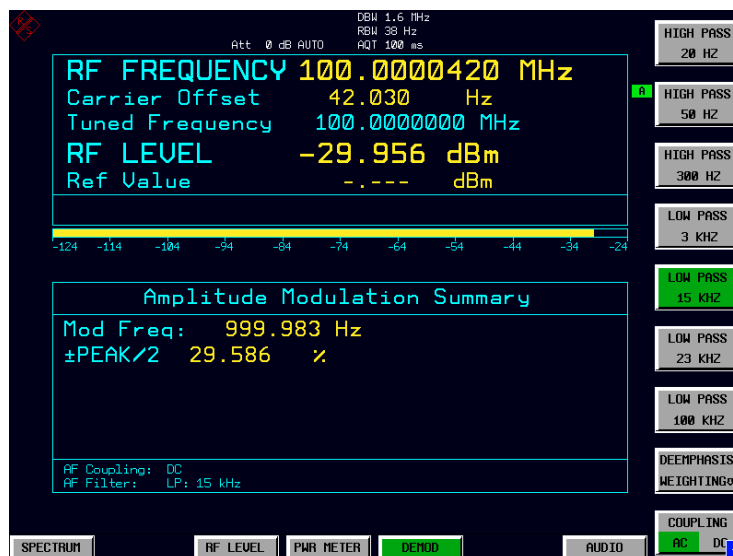
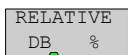
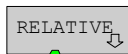
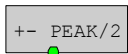
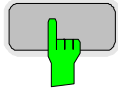

Fig.2-10 AM Modulation measurement in the DEMOD mode

- *In the FILTER menu press the LOW PASS 15 KHZ softkey again to switch the filter off.*



2. Relative Audio measurements – audio frequency response

- Press the *DEMOM* hotkey.

The analog demodulation menu is displayed.

- In the DEMOD menu press the *RELATIVE* softkey.

The RELATIVE menu is displayed. In the relative menu, only the detectors which have been switched on in the DETECTOR menu are available for relative measurements.

- In the RELATIVE menu press the +- *PEAK/2* softkey.

The actual measurement value of the detector will be saved as a reference value and the result display will change to a relative reading (indicated with Δ 0.00 %).

Change the modulation frequency to 50 kHz

- The following settings are used on the generator:

1. Select the AM Modulation, 50 kHz modulation frequency.

Relative display – Change the Unit to dB

- Press the *DEMOM* hotkey.

The analog demodulation menu is displayed.

- In the DEMOD menu press the *RELATIVE* softkey.

The RELATIVE menu is displayed.

- In the RELATIVE menu press the +- *PEAK/2* softkey.

The actual result display will change from a relative reading indicated in % to a dB reading.

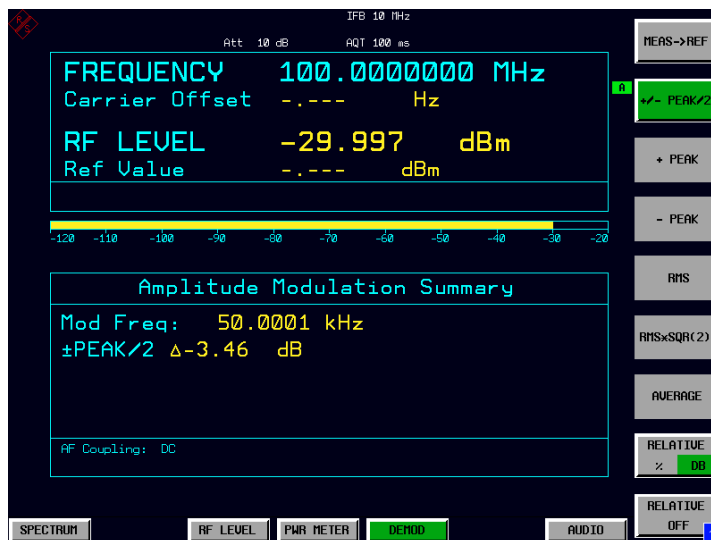
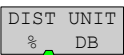
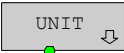
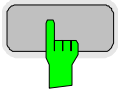
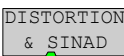
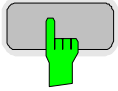

Fig.2-11 Relative measurement in the demod mode



3. Measure the harmonic distortion - Choosing the detector

- Press the *DEMOM* hotkey.
- In the DEMOD menu press the *DETECTOR SELECTION* softkey.

The DETECTOR SELECTION menu is displayed

The instrument is equipped with a wide range of detectors for measuring modulation signals. The peak detectors are a good choice for capturing the highest positive or negative peak within the measurement time, while the RMS and Average detectors are the best choice for measuring noise and residual modulation. The THD & SINAD detector measure the distortion of the demodulated audio signal. All detectors can be used in parallel.

- In the DETECTOR SELECTION menu press the *DISTORTION & SINAD* softkey.

Total Harmonic Distortion – Change the Unit to %

- Press the *AMPT* hardkey on the frontpanel.
- In the AMPLITUDE menu press the *UNIT* softkey.

The measuring receiver UNIT menu is displayed.

- In the UNIT menu press the *DIST UNIT % / DB* softkey.

The actual result display for the THD measurement will change from a “DB” reading to a “%” reading.

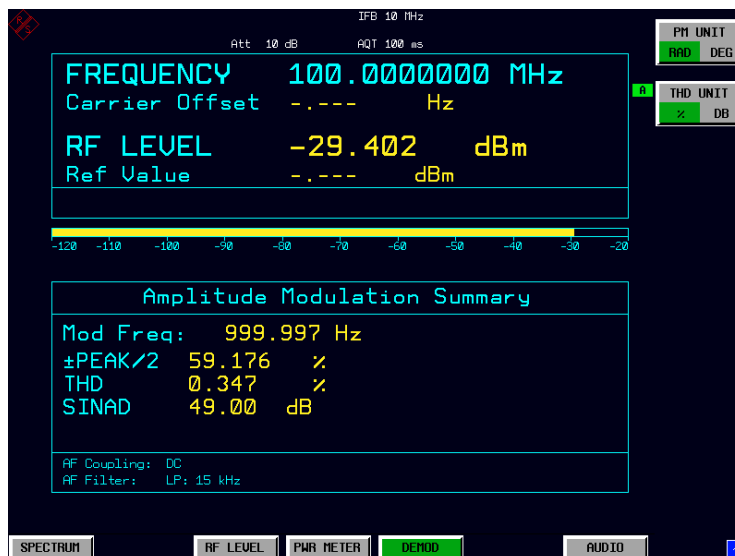

Fig.2-12 THD measurement in UNIT %

Example 4: Audio Measurements with the Audio Analyzer mode

Measurement

The FSMR includes an audio analyzer functionality. Measurements of audio signals will be performed in the audio analyzer mode with highest accuracy. The FSMR will automatically handle all required settings.

Main Receiver Functions

The audio analyzer functions are available in the Measuring Receiver *AUDIO*-mode. All required settings and evaluations can be reached from the *AUDIO* main menu.

Measurement Setup



Fig.2-13 Audio measurement setup

- **Connect the signal generator LF (low frequency) output with the FSMR Audio input.**

The following settings are used on the generator:

1. *PRESET* the generator.
2. Set LF output to ON .
3. Set the LF output level to 1 volt.
4. Set the LF output frequency to 1 kHz.

Measurement Sequence – Audio Measurements

The following steps are performed:

1. Measure the audio level and frequency.
2. Measure the frequency response of the audio filters.
3. Measure the influence of the input impedance.



- **Reset the instrument.**
- *Press the PRESET key.*

The main receiver menu is opened. The receiver mode is set.

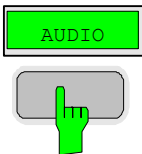

Switching to Audio Mode

- *Press the AUDIO hotkey.*

The audio menu is displayed. The audio measurement results are displayed in parallel, no further settings like frequency is required.

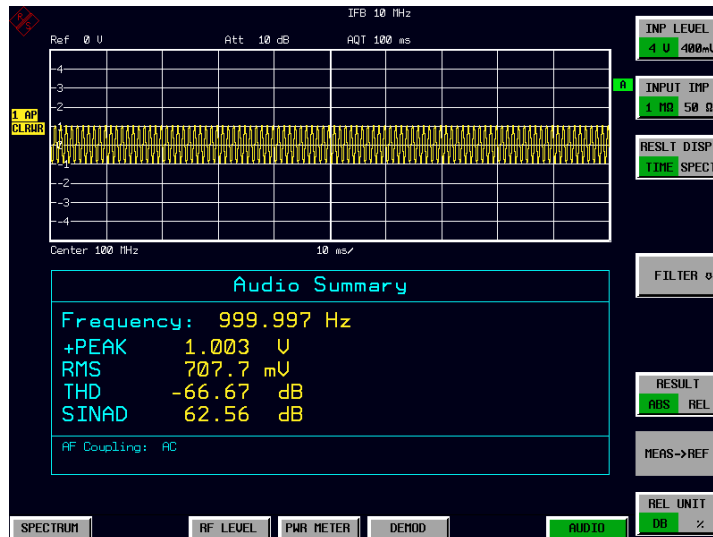
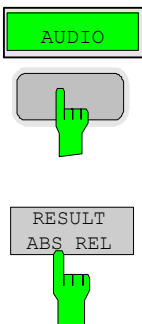

Fig.2-14 Audio measurement after Preset, Mode Audio



4. Relative Audio measurements

- Press the *AUDIO* hotkey.
- The audio menu is displayed.
- In the *AUDIO* menu press the *RESULT ABS REL* softkey.

The relative measurement function is enabled.

The actual measurement value of the detector will be saved as a reference value and the result display will change to a relative reading (indicated with Δ 0.00 dB). The unit can be changed with the *REL UNIT DB %* softkey in the audio menu.

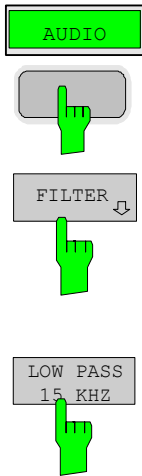

Limiting the bandwidth - Audio Filters

- Press the *AUDIO* hotkey.
The audio menu is displayed.
- In the *AUDIO* menu press the *FILTER* softkey.
The audio filter menu is displayed. To suppress unwanted broadband noise or harmonics of the signal, the bandwidth of the measurement can be limited with highpass and lowpass filters.
- In the *FILTER* menu press the *LOW PASS 15 KHZ* softkey.

Change the LF output frequency to 15 kHz

- The following settings are used on the generator:
- Set the LF output frequency to 15 kHz.

The audio frequency is now changed to the bandwidth of the active 15 kHz low pass filter. In the following measurement the frequency response of the audio low pass filter is measured.

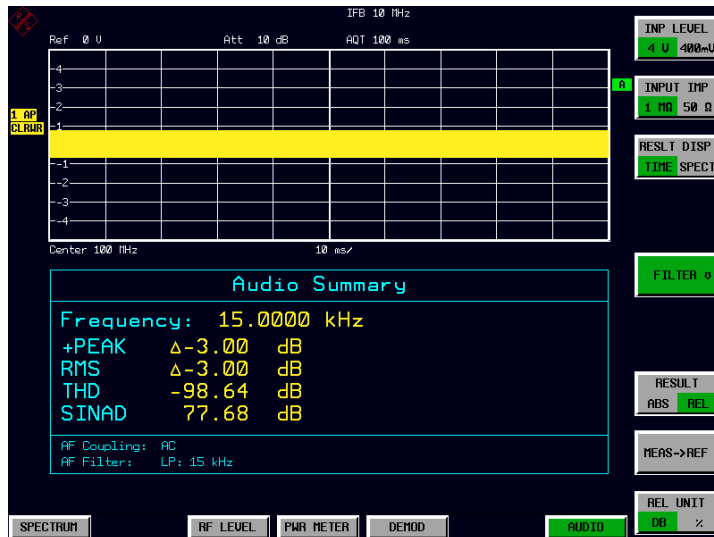

Fig.2-15 Audio measurement in relative mode

Contents - Chapter 3 "Manual Operation"

3 Manual Operation	3.1
The Screen	3.1
Diagram Area	3.2
Indications in the Diagram Area	3.3
Full Screen	3.9
Split Screen	3.9
Softkey Area	3.10
Hotkey Area	3.11
Calling and Changing the Menus	3.11
Setting Parameters	3.12
Numeric Keypad	3.12
Spinwheel and Cursor Keys	3.13
Selection and Setting of Parameters via Keys or Softkeys	3.14
Editing of Numeric Parameters	3.17
Entry of Alphanumeric Parameter	3.20
Editing with External Keyboard	3.20
Editing with Help Line Editor	3.21
Selection and Setting of Parameters via Tables	3.24
Menu Overview Receiver Mode	27
FREQUENCY Key	27
SPAN Key.....	28
AMPT Key	29
BW Key	30
SWEEP/MEAS Keys	31
Hotkey Menus	32
RF LEVEL Key	32
PWR METER Key.....	33
DEMODO Key.....	34
AUDIO Key.....	35
Menu Overview Spectrum Analysis Mode	36
FREQUENCY Key.....	36
SPAN Key.....	37
AMPT Key	38
MEAS Key	39
BW Key	40
SWEEP Key	41
Menu Overview another Keys	42
MKR Key	42
MKR-> Key	43
MKR FCTN Key.....	44
TRIG Key.....	45
TRACE Key	46
LINES Key.....	47

DISP Key.....	48
FILE Key.....	49
CAL Key.....	50
SETUP Key.....	51
HCOPY Key.....	52
Hotkey Menu.....	53
LOCAL Menu.....	53
Menu Overview Ext. Generator Control.....	54
Menu Overview Option Network Mode.....	55

3 Manual Operation

Chapter 3 provides an overview of the operating concept and the basic steps of manual operation of the R&S FSMR. This includes a description of the screen, of the control of menu and of the setting of parameters. An overview of the menus will be listed at the end of this chapter.

The functions of the menus are described in detail in Chapter 4. Chapter 2 contains a short introduction on step-by-step simple measurements. The remote control of the instrument is described in Chapters 5, 6 and 7

The operation of the spectrum analyzer is menu-controlled via keys, hotkeys and softkeys. The setting of the instrument and test parameters in the menu is made either directly via softkeys or by entry of values in entry fields and by selection in tables. The operating mode and the screen mode is selected via the hotkeys.

If required, data entry windows and tables are superimposed on the screen.

The Screen

The screen informs continuously on the results and parameters of the selected measuring functions. It shows the assignment of the softkeys and menus, which are required for setting the measuring parameters. The display of test results, the softkey labeling and the type of menu depend on the selected measuring function.

The screen is subdivided into three areas:

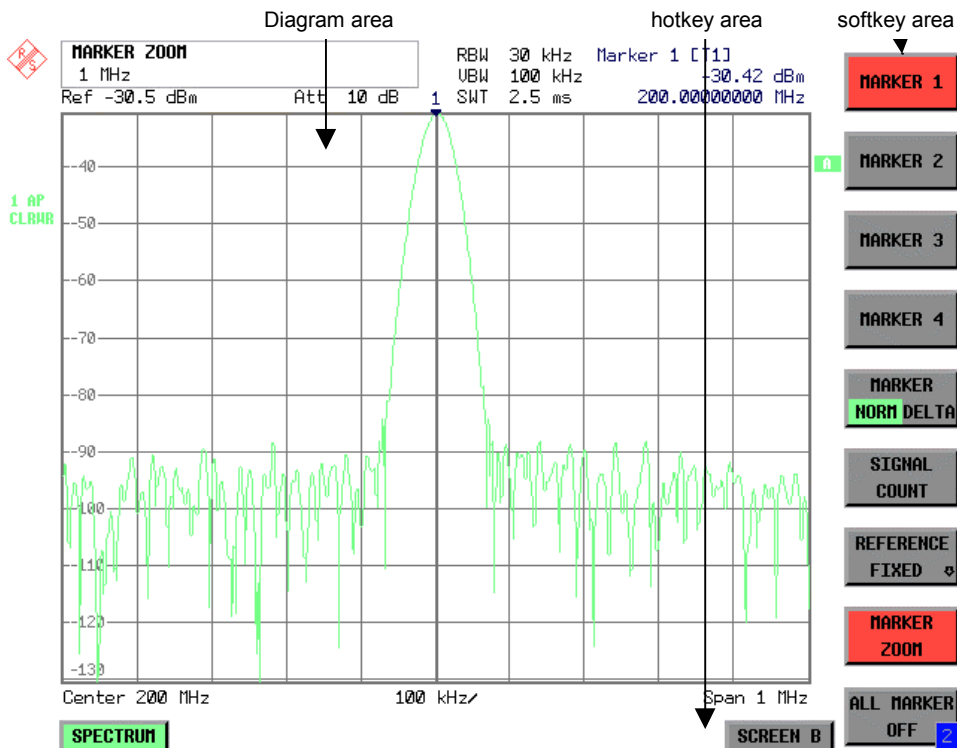

Fig. 3-1 Subdivision of screen

- Diagram area** This area contains the measuring diagrams and other measured-value information as well as the parameters and status information which are important for analysis of the results. In addition, message fields, entry windows and tables may be shown in this area.
- Softkey area** This area contains the instrument functions which can be selected via the softkeys. The softkey area is not superimposed by other graphics.
- Hotkey area** This area contains the available operating modes and screen modes. The hotkey area is not superimposed by other graphics.

Diagram Area

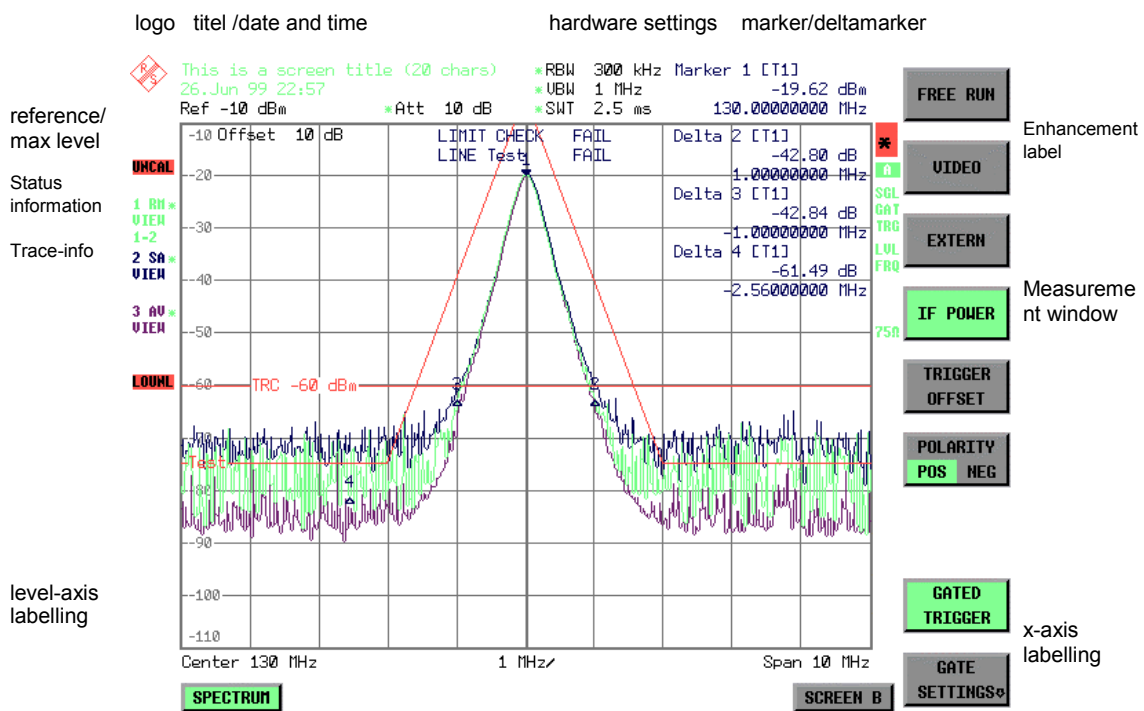

Fig. 3-2 Subdivision of the R&S FSMR screen in analyzer mode (without measuring diagram)

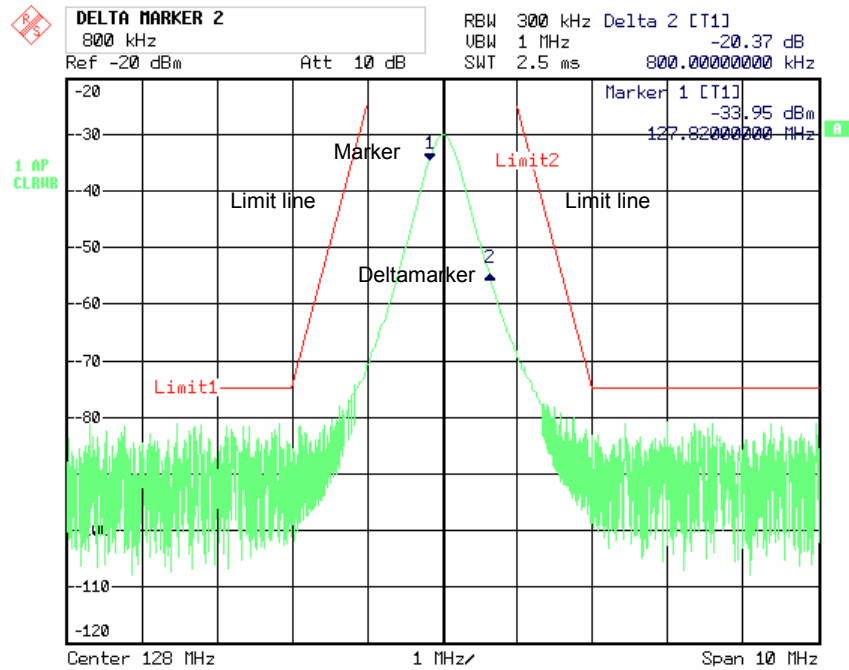

Fig. 3-3 Measuring diagram

Indications in the Diagram Area

The following graphic elements are displayed in the diagram area:

General indications	Indication of the logo
Logo	
Screen title	Indication of selected screen title
Date / time	Indication of date and time
Hardware settings	
Ref	Indication of the reference level
Offset	Indication of the offset of reference level.
Att	Indication of the set RF attenuation.
RBW	Indication of the set resolution bandwidth. If the bandwidth does not correspond to the value of the automatic coupling, a green asterisk "*" is prefixed to the field.
VBW	Indication of the set video bandwidth. If the bandwidth does not correspond to the value of the automatic coupling, a green asterisk "*" is prefixed to the field.
SWT	Indication of the set sweep time. If the sweep time does not correspond to the value of the automatic coupling an asterisk "*" is prefixed to the field. The colour of the asterisk turns red as soon as the sweep time falls below the value of the automatic coupling.

Marker/deltamarker	<p>This label displays the position of the last selected marker or deltamarker in the x and y-directions and the marker/deltamarker index. The square brackets contain the curve which the marker is assigned to and the active measuring function of the marker indicated. The measuring function of the markers in the second field is indicated by the following abbreviations:</p> <p>FXD reference fixed active PHN phase noise measurement active CNT frequency counter active TRK signal track active NOI noise measurement active MOD measurement of AM modulation depth active TOI TOI measurement active (3rd order intercept)</p>
Limit check	Indication of the result of the limit check.
X-axis labelling	Display of the x-scaling.
<pre>{10 MHz/DIV_____}</pre>	The distance between two grid lines is displayed in this label.
<pre>{Center 1.2345678901234 GHz}</pre>	The set center frequency or start frequency is displayed in this label depending on whether the keys FREQ/SPAN or the softkeys START/STOP were last pressed.
<pre>{Start 1.2345678901234 GHz}</pre>	If span = 0 Hz, the center frequency is always displayed.
<pre>{Span 1.2345678901234 GHz}</pre>	The set frequency range (SPAN) or the stop frequency is displayed, depending on whether the keys FREQ/SPAN or the softkeys START/STOP were last pressed.
<pre>{Stop 1.2345678901234 GHz}</pre>	If span = 0 Hz, the trigger moment (PRETRIGGER) is displayed.
<pre>{Trigger 1.234 ms}</pre>	

Status information	The status information on the left side of the diagram hint at irregularity (e.g. UNCAL)
#SMPL	"#SMPL" indicates that the relation Span / RBW is higher than 125 while the RMS detector is activated. In this case, a stable signal evaluation is no longer possible due to an insufficient number of A/D converter samples.
UNCAL	<p>⇒ reduce span or increase RBW</p> <p>"UNCAL" is indicated under the following circumstances:</p> <ul style="list-style-type: none"> • correction data are switched off (menu CAL, CAL CORR OFF). ⇒ switch on CAL CORR ON or PRESET • no valid correction data. This may occur after a cold start of the instrument following a firmware update. ⇒ record correction data • Sweep time too short for current instrument settings (span, resolution bandwidth, video bandwidth). ⇒ increase sweep time
OVLD / IFOVL	<p>OVLD is indicated when the input mixer is overloaded. ⇒ Increase input attenuation</p> <p>IFOVL is indicated when overload occurs in the IF signal path after the input mixer. ⇒ Increase reference level</p>
LOUNL / EXREF	<p>LOUNL is indicated when an error occurs in the frequency processing of the instrument.</p> <p>EXREF is indicated when the analyzer is configured for use of an external reference signal, but no reference signal is detected at the corresponding input.</p>
OVEN	OVEN is indicated when the crystal oscillator (option R&S FSMR-B4) has not yet reached its operating temperature. This indication vanishes after a few minutes after switch on.
Trace info:	<p>Every active measurement curve (trace ≠ BLANK) is allocated trace information of two or three lines at the left of the diagram. The trace information has the same colour as the measurement curve.</p> <p>The information on the currently selected trace is displayed in inverse video (see <i>TRACE - SELECT TRACE softkey</i>).</p>

<n> <detector> <*>
 <mode>
 <trace math>

n = trace number (1 ... 3)

detector = selected detector
AP: AUTOPEAK detector
PK: MAX PEAK detector
MI: MIN PEAK detector
SA: SAMPLE detector
AV: AVERAGE detector
RM: RMS detector
QP: QUASISPEAK detector

Example:

1 PK *
 CLRWR
 1-2

* = indicates that the selected detector does not correspond to that of the automatic coupling.

mode = indication of sweep mode
CLRWR: CLEAR/WRITE
MAXH: MAX HOLD
MINH: MIN HOLD
AVG: AVERAGE
VIEW: VIEW

Trace math = trace math active
1 - 2 trace 1 - trace 2
1 - 3: trace 1 - trace 3

Instrument settings
(Enhancement Labels)

Indication of user instrument settings which influence the measuring result and which are not immediately obvious when viewing the measured values.

- * The current instrument setting does not correspond to the one which applied when one of the displayed curves had been stored. This occurs under the following circumstances:
 - The instrument setting is modified while a measurement is being performed.
 - The instrument setting is modified in SINGLE SWEEP mode subsequent to the end of the sweep and no new sweep is started.
 - The instrument setting is modified after setting the trace to VIEW.

The display is retained until the cause is eliminated by the user. I.e., either a new sweep is started (SINGLE SWEEP mode), or the trace of interest is switched to BLANK.

A / B	Identification for screen A / B. When screen A / B is activated for the entry of test parameters, this label is highlighted.
SGL	The sweep is set to SINGLE SWEEP.
GAT	The frequency sweep is controlled via the <i>EXT TRIG/GATE</i> input of the instrument.
TRG	The instrument is not triggered in <i>FREE RUN</i> mode.
LVL	A level offset \neq 0 dB has been set.
FRQ	A frequency offset \neq 0 Hz has been set.
PRN	A printer output is active.
75 Ω	The input impedance of the instrument is set to 75 Ω .
EXT	The instrument is configured for operation with external reference
PA	The RF preamplification is switched on (option B23 or B25).

Entry fields:**Entry window**

The data entry window is superimposed in the left upper corner of the diagram area, if required. It covers the display of the title and the time. The field is used to enter numeric or alphanumeric device parameters.

Tables

The tables are superimposed in the diagram area, if required. They are used for displaying and configuring device parameters.

Message windows:**Message field**

Message fields provide notes on measurements, e.g. results of the limit check (PASS/FAIL).

These notes are no error messages, which are indicated as system messages.

They can be masked out by pressing the *ESC* key.

System messages

System messages indicate warnings and error messages.

Message without action field:

These system messages contain only arbitrary information. They hint at events which are of interest for the user but do not affect the measurement or functioning of the instrument.

They are deleted either automatically after a predefined time has passed (3 seconds) or upon any keystroke or mouse click.

Message with action field:

These system messages require a decision to be taken by the user. They are not deleted until any action has been selected. Deletion of the message initiates the action selected and appropriate measures to be taken. The action field consists of one (OK), two (OK/CANCEL) or three (arbitrary) buttons.

The user may select one of the buttons using the cursor keys and initiate the associated action by means of the unit keys. The *ESC* key is used to acknowledge the message without releasing any action.

Traces:**1 to 3**

Up to 3 traces in each measurement diagram can be displayed simultaneously.

Limit lines

Limit lines are used to mark level curves or spectral distributions which must not be exceeded or dropped below.

The R&S FSMR provides two display modes:

- Full Screen: 1 window, the measurement is performed in the active diagram.
- Split Screen: 2 windows, the measurements are performed in both diagrams.

Full Screen

In the full-screen mode, the settings and measurements are performed in the active visible window. All indications on the screen refer to this window. The designation (SCREEN A or SCREEN B) is inserted as enhancement label A or B on the right diagram margin.

Switching between the windows is by means of *SCREEN A/B* hotkey. The current measurement is terminated when its window is blanked out.

Switching from split-screen to full-screen mode is performed in menu *DISP*.

Split Screen

In Split Screen mode, the screen is divided into two halves.

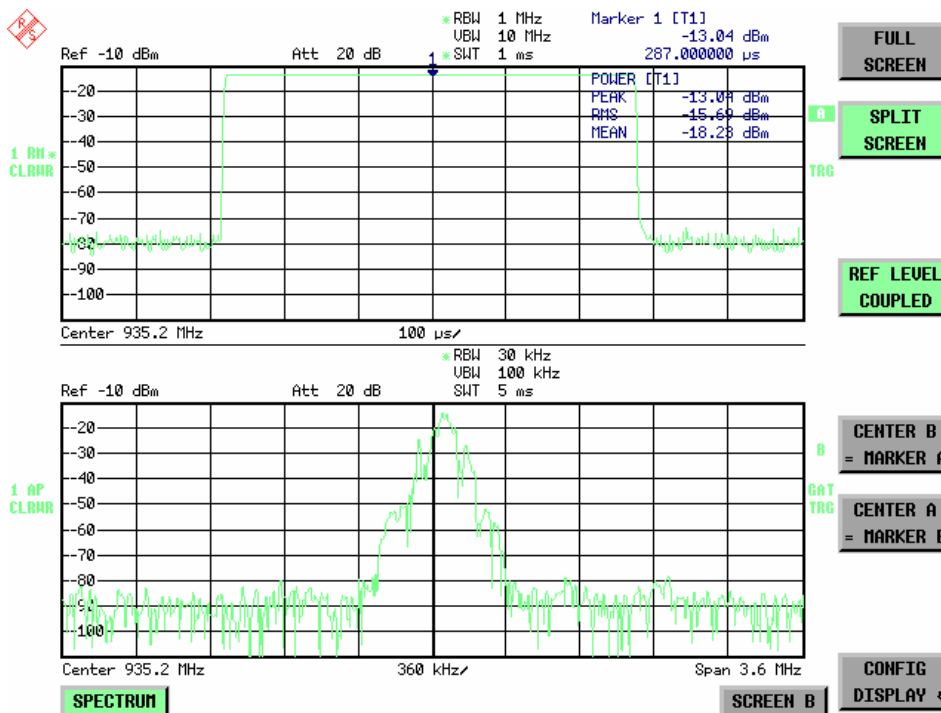

Fig.3-4 Subdivision of the screen in Split Screen mode

The upper half is assigned Screen A, the lower one Screen B. The settings for measurement can be selected independently for both screens. E.g., a spectrum may be displayed in Screen A and a time amplitude in the time range is displayed in Screen B.

The indications which are valid only for one window appear in the margin of the associated diagram. Indications which are valid for the two windows are displayed between the diagrams.

The window for entry of the measuring parameters or the marker operation is selected using the *SCREEN A/B* hotkey. The measurements are simultaneously performed in the two windows irrespective of the currently active one.

Switching from full-screen to split-screen mode is performed in menu *DISP*.

Softkey Area

The softkeys are assigned to the nine keys on the right side of the display
 The setup of the softkey area is independent of the operating mode. It consists of the following graphic elements:

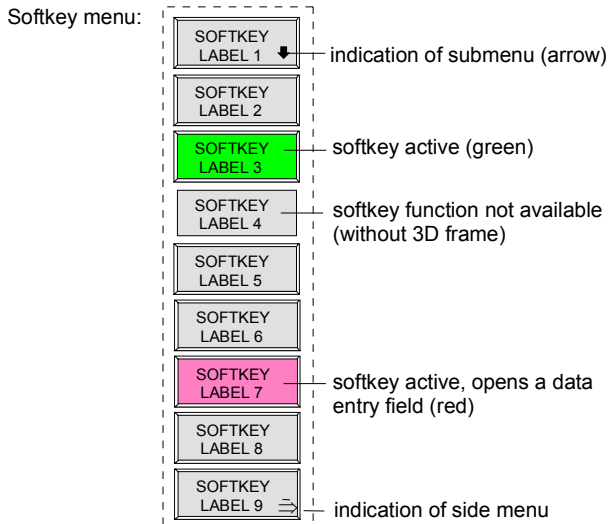

Fig.3-5 Setup of the softkey area

The softkeys have different functions depending on the instrument state. Therefore, their labeling can be varied. The labeling of all softkeys which call a submenu includes a ↓ arrow.
 The function and current state of the softkeys is indicated in the label by different texts and colors. The color assignment is factory-set as follows:

Table 3-1 Factory-set color assignment of soft keys

Softkey color	Meaning
gray	Softkey switched off
green	Softkey switched on
red	Softkey switched on and data entry active

These colors can be changed by the user as desired in the *DISP - CONFIG DISPLAY* menu.

A softkey is switched on or off by pressing the respective hardkey (see following section "Setting the Parameters").

Softkeys are masked out, too, if the functionality which they represent is not available. A distinction has to be made between two cases:

- If an instrument function depends on an option, and if this option is not fitted, the associated softkey is masked out,.
- If the instrument function is not available temporarily due to specific settings, the softkey is displayed without the 3D frame.

The label  on the right lower corner of the softkey area indicates that a side menu is available. The side menu is called by pressing the *NEXT* key.

Hotkey Area

Hotkeys are allocated to the eight keys on the bottom margin of the screen. They change between modes and the active diagrams.

The menu only shows the hotkeys which are actually used:

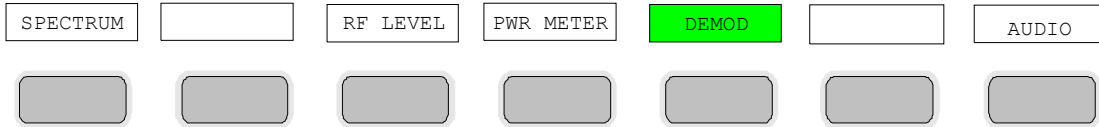

A keystroke activates the associated hotkey. An activated hotkey changes its frame:

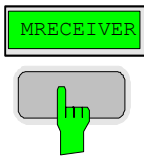

Calling and Changing the Menus

The operation of the spectrum analyzer is menu-controlled via keys and softkeys. Various softkey menus are displayed depending on the instrument status. The individual menus constitute the so-called menu tree. The top menu (the root of the menu tree) is always called by means of a keystroke. Arrows at the lower edge of the softkey area indicate whether a supplementary menu can be entered or not.

Softkeys with an arrow allow for branching into further menus (so-called submenus): The field "→" at the lower right side of the softkey area indicates that this menu has a side menu.

The menu change keys on the front panel below the softkey area allow for switching between the main menu and the side menus and submenus.

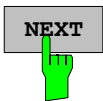

The *NEXT* key calls the side menu.



The *PREVIOUS* key returns to the next higher menu.

Several menus provide for automatic change, i.e., return to the next higher menu is caused automatically after pressing a softkey.

Selection of a submenu is always effected via a softkey.

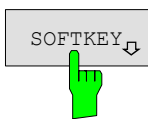

The labeling of all softkeys which call a submenu includes a ↓ arrow.

Setting Parameters

Parameters are set either by simple selection (selection parameters) or by (alpha)numeric entries in data entry windows or tables.

The numeric keypad on the front panel, an external keyboard (optional), a spinwheel and the cursor keys are provided for the entry of instrument parameters in an entry window or in a table.

The external keyboard is optional. If it is not fitted, the help line editor is called automatically for entry of alphanumeric parameters. The help line editor provides for selection of individual letters and a number of special characters which are copied into the actual entry window.

Numeric Keypad



The numeric keypad is provided for entry of numeric parameters. It contains the following keys:

- Number keys 0 to 9
- Decimal point
Inserts a decimal point "." at the cursor position.
- Sign key
Changes the sign of the mantissa or exponent of a numeric parameter.
A "-" is inserted at the cursor position in case of an alphanumeric parameter.
- Unit keys (*GHz/-dBm*, *MHz/dBm*, *kHz/dB* and *Hz/dB*)
 - Provide the numeric value entered with the selected unit and terminate the entry.
The unit keys are all assigned the value "1" for dimensionless quantities or for level entries (e.g., in dB). The unit keys thus assume the function of an *ENTER* key. The same applies for an alphanumeric entry.
 - Open and close the selection windows of tables.
- *BACK* key
 - Deletes the character left to the cursor with numeric entry.
 - Allows for toggling between the current and the previous values subsequent or prior to entry (UNDO function).
- *ESC/CANCEL* key
 - Aborts the entry before it has been terminated. The previous value is restored.
 - Closes the entry field after termination of input.
 - Closes system messages.
- *ENTER* key
 - Terminates the input of dimensionless quantities. The new value is set.

Note: The *ENTER* keys assumes the function of the *Hz* key for frequency input, and the function of the μ s(*kHz*) key for time input.

Spinwheel and Cursor Keys

The spinwheel and the cursor keys are arranged besides the numeric keypad.



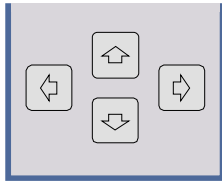

The spinwheel has various functions:

- With numeric entry, the instrument parameter is incremented (turning clockwise) or decremented (turning counterclockwise) at a defined step size.
- In tables, the spinwheel can be used to shift the cursor horizontally or vertically when no entry window is open. The direction (horizontal/ vertical) is switched over using the cursor keys.
- The spinwheel is used with the help-line editor to select the individual letters.
- It can be used to shift markers, display lines, limit lines etc.
- Pressing the spinwheel terminates the input of parameters.



In tables, the cursor keys are used to shift the cursor between the lines and columns of the table.

The keys  and  are used to shift the cursor inside the entry window to reach a particular position in the string.

The keys  and 

- increase or decrease the value of a parameter for numeric input .
- switch between editing line and help line editor for alphanumeric input.

Selection and Setting of Parameters via Keys or Softkeys

The selection of parameters and their settings is effected by means of a key, a softkey or in a table depending on the hierarchical level of the menu they are assigned to. Selection and setting of parameters in tables is described in section "Selection and Setting of Parameters in Tables".

Selection via key

Most keys of the network analyzer are used to enter menus where the selection and the settings are made. Few settings can be made directly by means of a keystroke, only.

Example: Call up of preset settings

- Press *PRESET* key

The spectrum analyzer is brought into a predefined initial state.



Selection via softkey

In most cases the selection is made by pressing the respective softkey. There are various alternatives of making the selection:

1. The softkey is active or inactive.

Example: Switching on/off the frequency counter

- Press *MKR* key.
- Press *SIGNAL COUNT* softkey.

Each time the softkey is pressed, the marker info list is switched on or off. If the softkey is active (= marker info list on), it is illuminated.

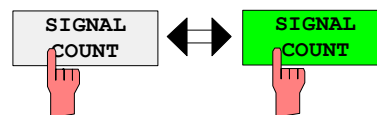

2. The softkey acts like a toggle switch, each pressing changes the active selection.

Example: Selection of the reference (internal or external)

- Press *SETUP* key.
- Press *GENERAL SETUP* softkey, the *GENERAL SETUP* submenu is opened.
- Press *REFERENCE INT/EXT* softkey.

With each pressing, the checkmark on the softkey changes from *INT* (internal reference) to *EXT* (external reference) and vice versa. When in the active setting the softkey menu item is illuminated.

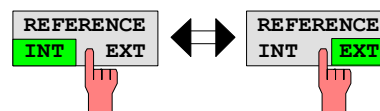

3. Various softkeys act like selection switches. Only one softkey may be active at a time.

Example: sweep setting

- Press *SWEEP* key.
- Press *CONTINUOUS SWEEP* softkey.

The continuous sweep is thus set. The *CONTINUOUS SWEEP* softkey is colored (factory-set: green). The second alternative, a series of n sweeps according to the trigger definition, can be selected via the *SINGLE SWEEP* softkey in the same menu. Only one of the two softkeys can be active at a time, the softkeys thus act like selection switches.

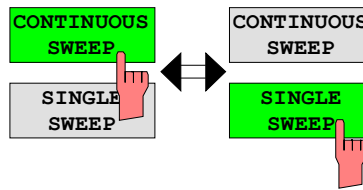

4. The softkey is used to select the parameter, the setting is made in an alphanumeric data entry window.

Example: SWEEP COUNT parameter

- Press *SWEEP* key
- Press *SWEEP COUNT* softkey.

The window for entering the number of sweeps for the *SINGLE SWEEP* mode is opened. The softkey is colored (factory-set: red). (Data entry is described in the next section).

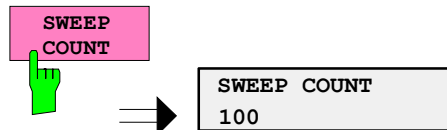

4. The softkey is used to select the parameter, the setting is made in an (alpha)numeric data entry window. The softkey function is switched on. To switch off the function, the softkey has to be pressed again.

Example: parameter MARKER

- Press *MRK* key.
- Press *MARKER 1* softkey.

The window for entering the marker frequency is opened. The softkey is colored (factory set: red). Marker 1 is switched on and the peak search is started.



- Press *MARKER 2* softkey.

The entry window for the marker frequency of marker 2 is opened. The softkey is colored (red), marker 2 is switched on, and the *MARKER 1* softkey turns green.

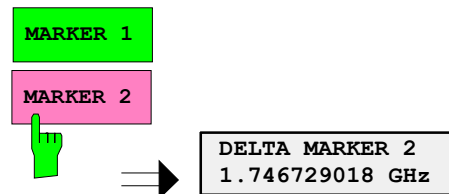

- Press *MARKER 1* softkey again.

Marker 1 is switched off.

5. The softkey selects the parameter, the setting is made in a selection table.

Example: Selection of the sorting criteria of a file list

- Press *FILE* key.
- Press *FILE MANAGER* softkey.
- Press *SORT MODE* softkey.

A selection table is displayed. The softkey is colored (factory-set: red). (operation see below).

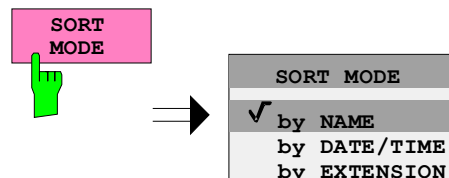

Editing of Numeric Parameters

The entry of numeric values is always made in a data entry window, which is displayed automatically after selection of the parameter.

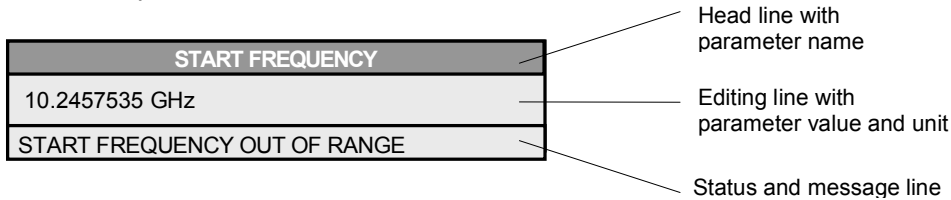

The headline indicates the name of the instrument parameter, which has been selected. The entry is made in the editing line. Subsequent to calling the entry window, the current parameter value including the unit is displayed left-justified in the editing line. Status and error messages which refer to the current entry are displayed in the third and (optionally) fourth line.

Note: Entry windows may be represented transparent (cf. DISPLAY - CONFIG DISPLAY menu)

Entry of a numeric value

- Call data entry window (cf. selection of parameters)
The editing line indicates the current value

Example: center frequency (frequency-sweep mode)

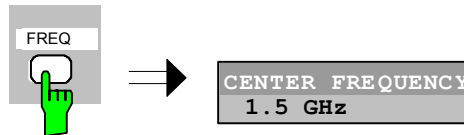

Entry via number keys

- Enter required value via number keys.

Example:

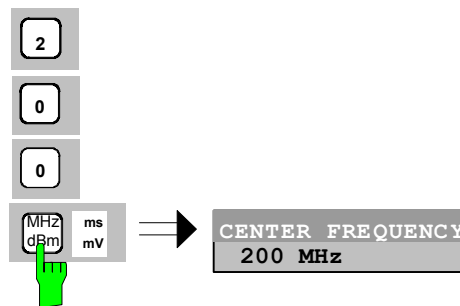

Entry via cursor keys

- Cursor  or  until obtaining the required value.

Example:

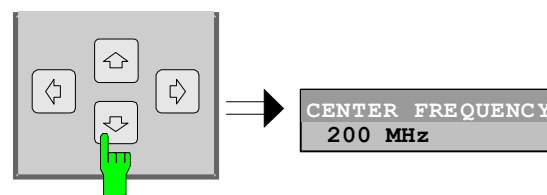

- Entry via spinwheel
- Rotate the spinwheel until reaching the required value.
The variation step size increases with increasing rotational speed.
 - Turning the spinwheel clockwise increases the value, turning it counterclockwise decreases the value.

Example:

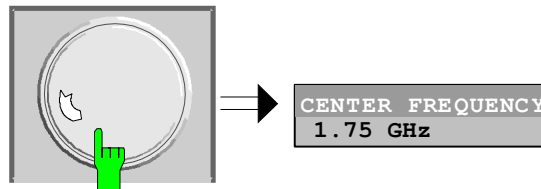

Note: When the value is modified by means of the spinwheel or the cursor keys the new value is immediately set.

Terminating the entry

- Press one of the unit keys
The unit is entered in the entry window and the new setting is accepted by the instrument.

For dimensionless quantities:

- Press the ENTER key or the spinwheel
The new setting is accepted by the instrument.

A few data entry windows close automatically whereas others like the entry window for the start frequency remain open even after termination of the entry. They can be closed by pressing the ESC key.

If an error occurs, a corresponding error message is displayed in the status line of the entry window, e.g., "Out of range", "Value adjusted", etc. In this case, the new value is not accepted for the instrument setting.

Example:

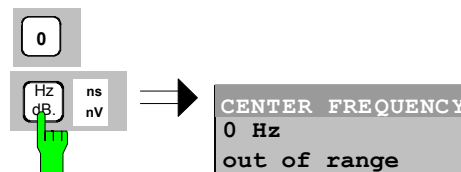

Correcting the entry

- Deleting an entry
- Position the cursor beside the digit which is to be deleted using the cursor keys \leftarrow or \rightarrow .
 - Press the BACK key. The entry left to the cursor is deleted.
 - Enter new numbers. The number is inserted to the left of the cursor, the other numbers are shifted right.

Restoring the original value

- Press the *BACK* key

For numerous parameters, the data administration of the instrument stores the previously valid parameter value in addition to the current value. The *BACK* key can be used to toggle between these two values. This applies for terminated entries as long as the data entry window is displayed.

Aborting the entry

- Press *ESC* key

The original parameter value is restored. The new entry is deleted.

- Press *ESC* key again

The entry window is closed, the original value remains active.

or

- Press any key or any softkey (even the softkey which has opened the entry window).

The entry is aborted and the entry window is closed. The original value remains active.

Entry of Alphanumeric Parameter

A help-line editor or an external keyboard (optional) are provided for the entry of alphanumeric instrument parameters.

The spinwheel and the exponent key have no function with alphanumeric entry. All unit keys assume the function of an ENTER key.

The entry is always made in a data entry window which is displayed automatically upon selection of the parameter. The editing line comprises 60 characters. Up to 256 characters may be entered. If a text exceeds 60 characters the contents is shifted automatically 20 characters left or right when the left or right margin of the editing line is touched by the cursor.

Editing with External Keyboard

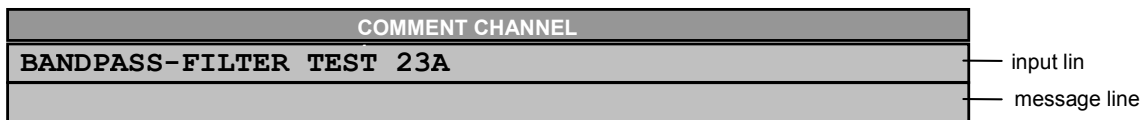

Entry of text

- Select parameter.
The data entry is active automatically upon calling the data entry window. The cursor is positioned at the beginning of the previous entry.
- Press the required character on the keyboard.
The character is inserted prior to the cursor.
- Enter further characters

Correcting the entry

- Delete the entry using the *DELETE* key or *BACKSPACE* key.

Terminating the entry

- Press the *ENTER* key of the external keyboard
The data entry window is closed and the new value is accepted for the instrument.

Aborting the entry

- Press the **ESC** key on the front panel
- or
- any softkey.
- The data entry window is closed, the original value is retained.

Editing with Help Line Editor

If the external keyboard is not fitted, the help line editor is called automatically with entry of alphanumeric parameters. The help line editor is an extension of the alphanumeric entry window. It contains the complete alphabet with uppercase and lowercase letters as well as special characters in two lines of 52 characters, each. Individual letters and a series of special characters can be selected in the help line editor and copied into the entry line.

The help line editor comes in two versions:

Version 1:

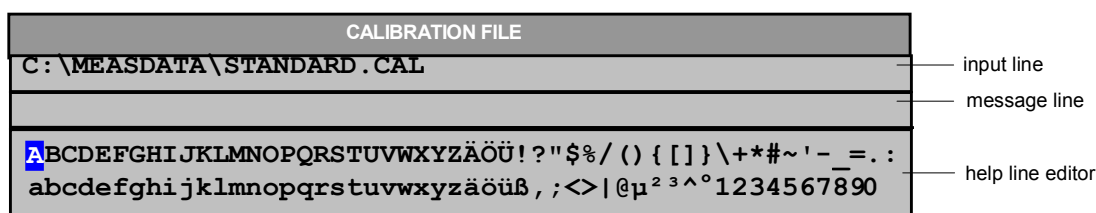

The cursor keys or toggle between entry in the editing line and selection in the help line editor.

Entry of text

- Select parameter.
The data entry is active automatically upon calling the data entry window. The cursor is positioned on the left in the editing line.
- Position the cursor in the help line editor using the cursor key. .
The cursor marks the first letter of the editor.
- Locate the cursor on the character which is to be entered into the editing line using the cursor keys or or the spinwheel.
- Press the *ENTER* key or the spinwheel.
The character is entered in the editing line.

Correcting the entry

- Locate the cursor in the editing line using the cursor key .
- Position the cursor after the character which is to be deleted using the cursor keys and .
- Press the *BACK* key.
The entry left to the cursor is deleted.

Terminating the entry

- Locate the cursor in the editing line using the cursor key .
- Press any unit key or the spinwheel.
The data entry window is closed, the new entry is accepted by the instrument.

Aborting the entry



- Press the *CLR* key.
The data entry window is closed, the previous entry is retained.

Version 2:





													1	2	3	4	5	6	7	8	9	0
A	B	C	D	E	F	G	H	I	J	K	L	M	:	\	.	/	^	+	-	=	,	
n	o	p	q	r	s	t	u	v	w	x	y	z	<	>	()	{	}	[]	#	~
SPACE													«	»	BACK		EXIT					

The entry area consists of two parts:

- the editing line
- the character selection field

The cursor keys  or  are used to toggle between entry in the editing line and the character selection field.



Entry of text

- Select parameter.
The data entry is active automatically upon calling the data entry window. In tables, the help line editor is accessed by the cursor key .
- In the editing line, the cursor is positioned at the beginning of the current entry.
- Position the cursor to the character selection field using the cursor key .
- The cursor highlights the first letter of the editor.
- Position the cursor to the character to be entered in the editing line by means of the cursor keys  or  or the spinwheel.
- Press the *ENTER* key or the spinwheel.
The character will be entered in the editing line.

Correcting the entry (Version 1)

- Move to the character << in the character selection field using the spinwheel.
- Position the cursor behind the character to be deleted by moving and pressing the spinwheel on << and >>.
- Move to the *BACK* field using the spinwheel and press the spinwheel.
The entry to the left of the cursor in the editing line will be deleted.

**Correcting the entry
(Version 2)**

- Position the cursor to the editing line by means of the cursor key .
- Position the cursor after the character to be deleted by means of the cursor keys  and  or with the spinwheel.
- Press the *BACK* key.
The entry to the left of the cursor will be deleted.

**Terminating the entry
(Version 1)**

- Select the EXIT field using the spinwheel and press the spinwheel.
The data entry window will be closed; the new entry will be accepted by the instrument.

**Terminating the entry
(Version 2)**

- Move the cursor to the editing line using the cursor key .
- Press one of the unit keys or the spinwheel.
The data entry window will be closed; the new entry will be accepted by the instrument.

Interrupting the entry

- Press the *ESC* key.
The data entry window will be closed; the previous entry will be retained.

Selection and Setting of Parameters via Tables

The spectrum analyzer uses numerous tables for display and configuration of instrument parameters.

The tables differ considerably in the number of lines, columns and inscriptions. The basic steps of operation for the selection and setting of parameters are, however, the same for all tables. Shown below is the typical entry of parameters into a table.

Note:

Most of the tables are coupled to a softkey menu which provides further functions for editing table entries such as deletion of tables, copying of lines or columns, marking of table elements, restoring default states.

The definition of individual tables and the operation of particular editing functions can be looked up in the description of the corresponding softkey menu.

1. Activating the table

- If the menu has only one table, the latter is activated automatically subsequent to calling this menu in most cases and the marking cursor is positioned to the top field of the left column.
- If the menu contains various tables, the table of interest must be selected using the softkey which is labeled with the title of the table.

2. Selection of the parameter

LIMIT LINES				
NAME	COMPATIBLE	LIMIT CHECK	TRACE	MARGIN
GSM22UP	✓	off	1	0 dB
✓ LP1GHz		on	2	0 dB
✓ LP1GHz	✓	off	1	0 dB
MIL461A		off	2	-10 dB

marking cursor

Selection of the parameter (or the setting) is made using the marking cursor.

- Press the cursor keys to move to the wanted field.

or

- Rotate the spinwheel until the wanted field is marked. The cursor keys are used to specify the direction of the spinwheel movement (horizontal or vertical)

When shifting the cursor, elements may be skipped which can not be edited. Table elements, which can not be selected are indicated by a different color.

- Press the *ENTER* key or the spinwheel.
The parameter/the setting has been selected.

The selected parameter can be edited the way described below:

3. Editing the marked parameter

LIMIT LINES				
NAME	COMPATIBLE	LIMIT CHECK	TRACE	MARGIN
GSM22UP	✓	off	1	0 dB
✓ LP1GHz		on	2	0 dB
✓ LP1GHz	✓	off	1	0 dB
▲ MIL461A		off	2	-10 dB

checkmark

TRACE
1
✓ 2
3

MARGIN
-10 dB

a) Toggling between two states

If an element of a table can be switched on and off only, the unit keys are used to toggle between these two states.

- Press one of the unit keys.
The table element is switched on and provided with a checkmark. (✓).
- Press one of the unit keys once more.
The table element is switched off.

or

- Press one of the unit keys.
The table element is switched on, "on" is displayed.
- Press one of the unit keys once more.
The table element is switched off, "off" is displayed

b) Opening a data entry window

If a table entry consists of an (alpha-) numeric value, the corresponding entry window will be opened after selecting the numeric value by pressing the *ENTER* key or the spinwheel.

Note 1: For numeric instrument parameters, the editing operation may be started by entering any number or letter on the front panel or on the external keyboard. In this case, the data entry window is opened automatically.

Note 2: For alphanumeric table fields for which the help line editor version 2 is required, the help line editor will be opened by pressing the *CURSOR DOWN* key after *ENTER*.

c) Opening a selection table

If a table entry may have various states (e.g., colors from a color pallet, fixed filter bandwidths, etc.), a table indicating all possible states is displayed with selection. The current state is and marked by a checkmark and by the cursor.

➤ Set the cursor to the desired setting.

➤ Press one of the unit keys.

The setting is switched on and marked (✓). The selection table closes and the value is transferred to the original table. The cursor is positioned automatically on the next table element.

Abortion of entry

➤ Press the *ESC* key.

The current entry/selection is aborted and the original setting is restored.

Scrolling

Some tables contain more entries than can be displayed on one screen page. In this case, a **scrollbar** is displayed at the right margin of the table, whose slider shows the current position in the text.

➤ Actuate the *PAGE UP* or *PAGE DOWN* softkeys.

The table is paged forward or back by one page.

➤ Press cursor key  or .

The table is scrolled up or down by one line.

Menu Overview Receiver Mode

The following sections gives a graphical overview of the R&S FSMR menus. Side menus are marked by an arrow directed to the left/right, submenus by an arrow showing upwards. The menus appear in the order corresponding to the arrangement of keys on the front panel. The available hotkeys and the LOCAL menu appearing during the remote control of the instrument are also displayed.

The functions of menus are described in detail in Chapter 4. The IEC/IEEE-bus command associated with each softkey is indicated. In addition, the softkey list at the of Chapter 6 gives the assignment of IEC/IEEE-bus commands to softkeys.

FREQUENCY Key

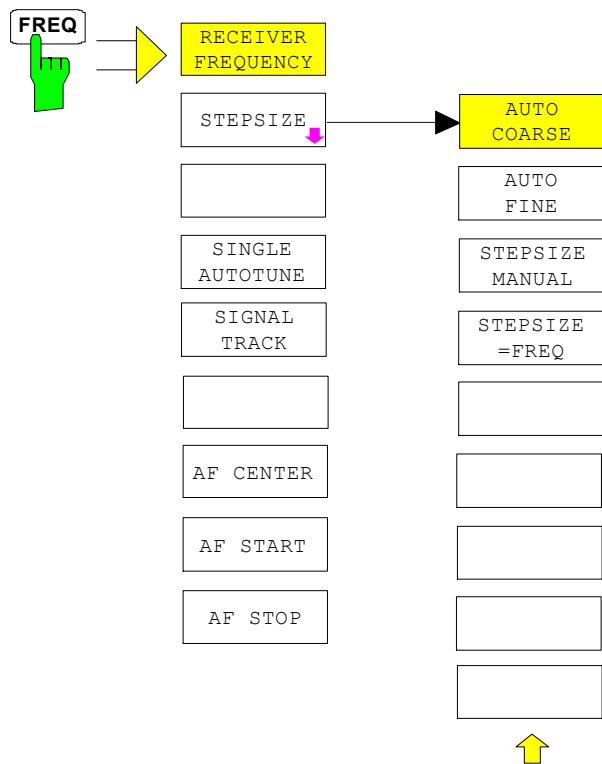

SPAN Key

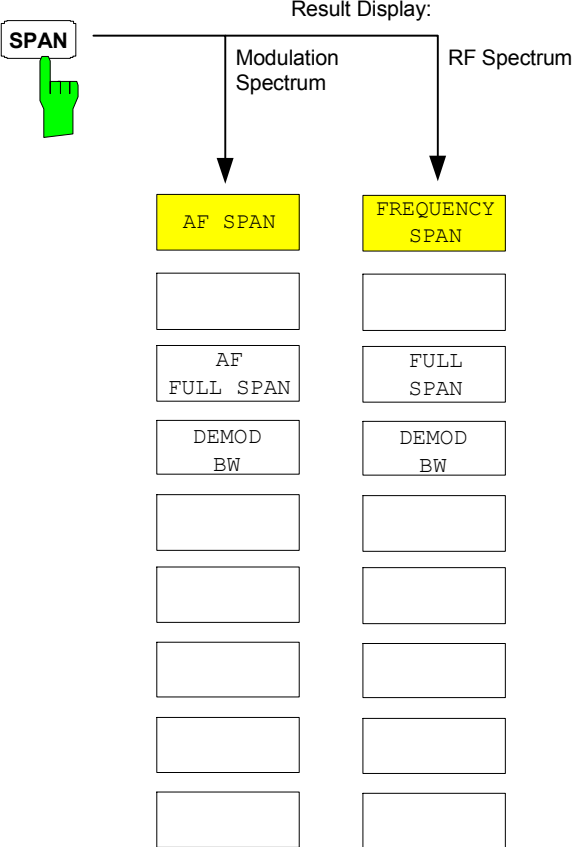

AMPT Key

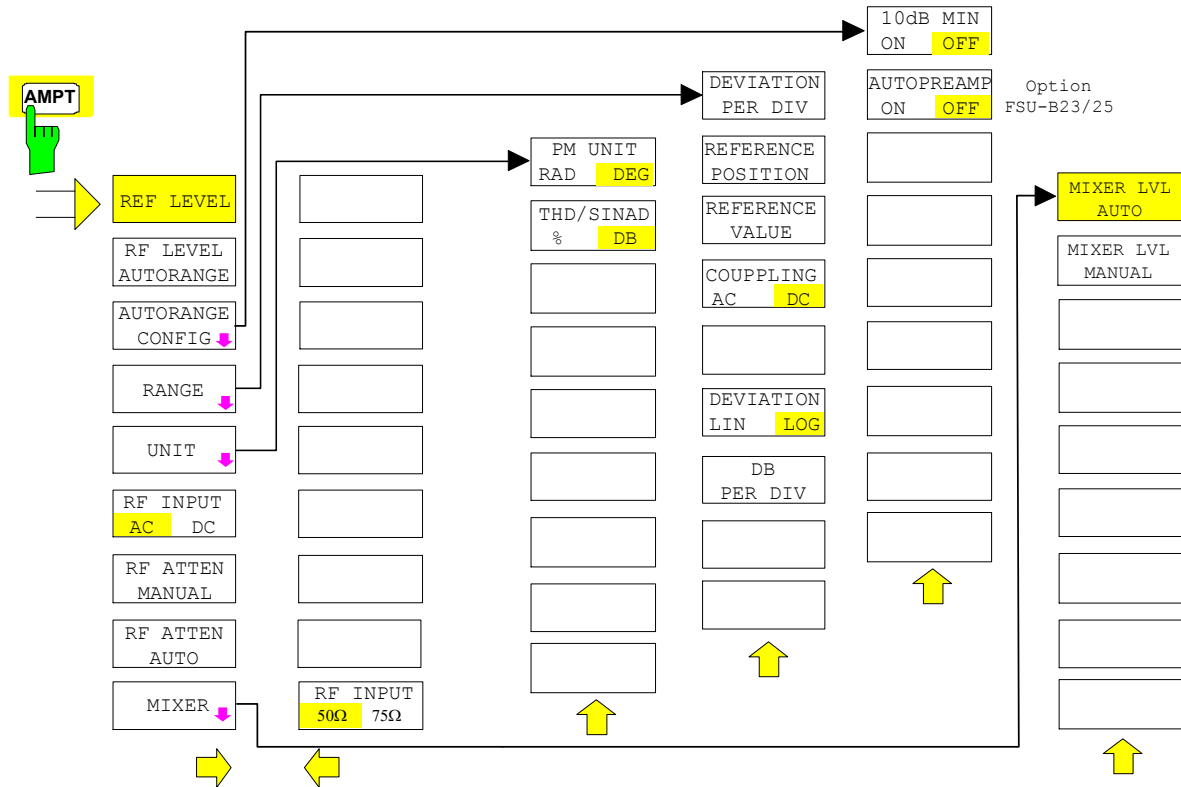

BW Key

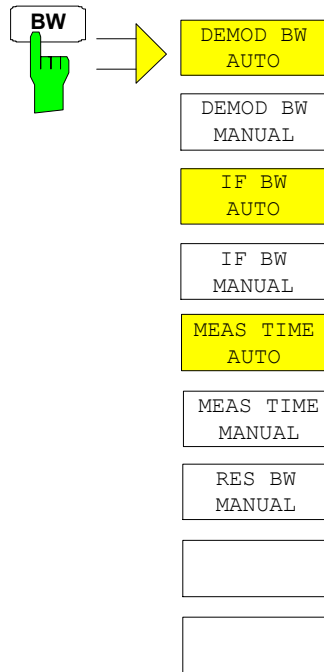

SWEEP/MEAS Keys

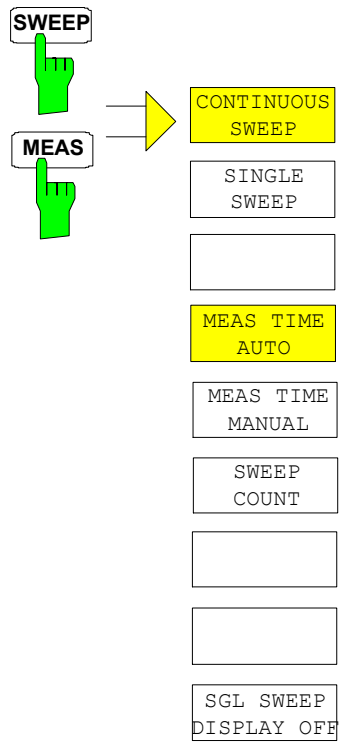

PWR METER Key

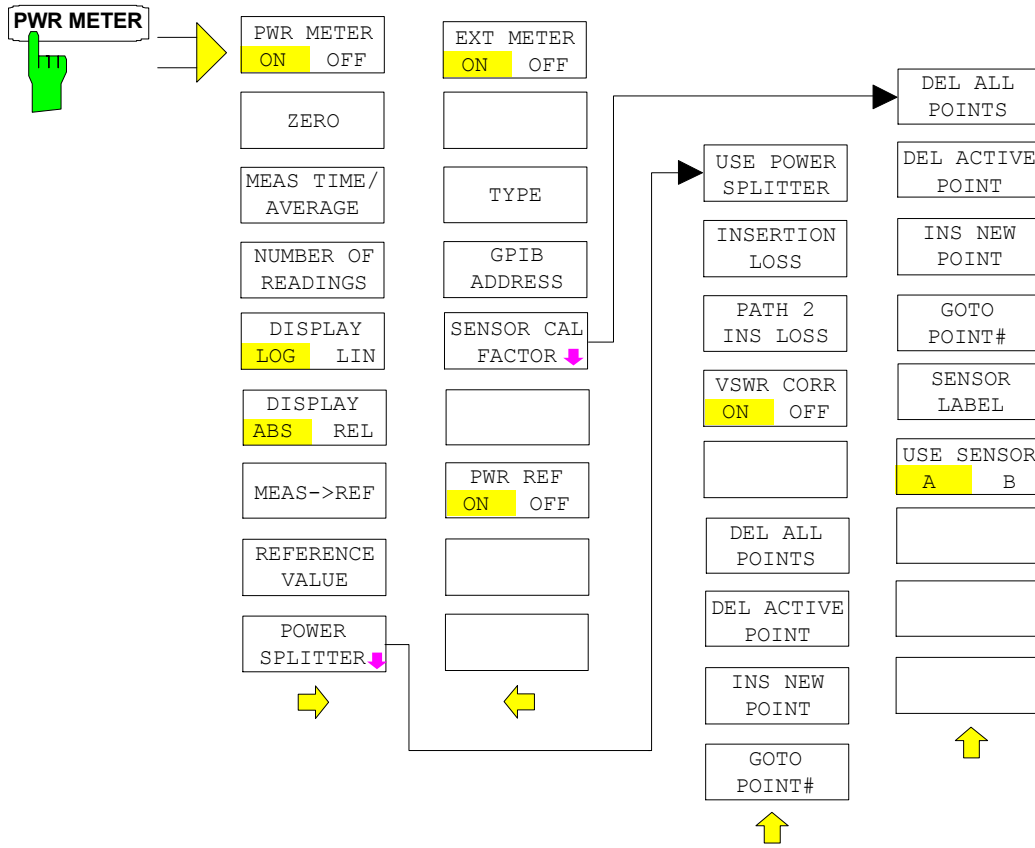

DEMOD Key

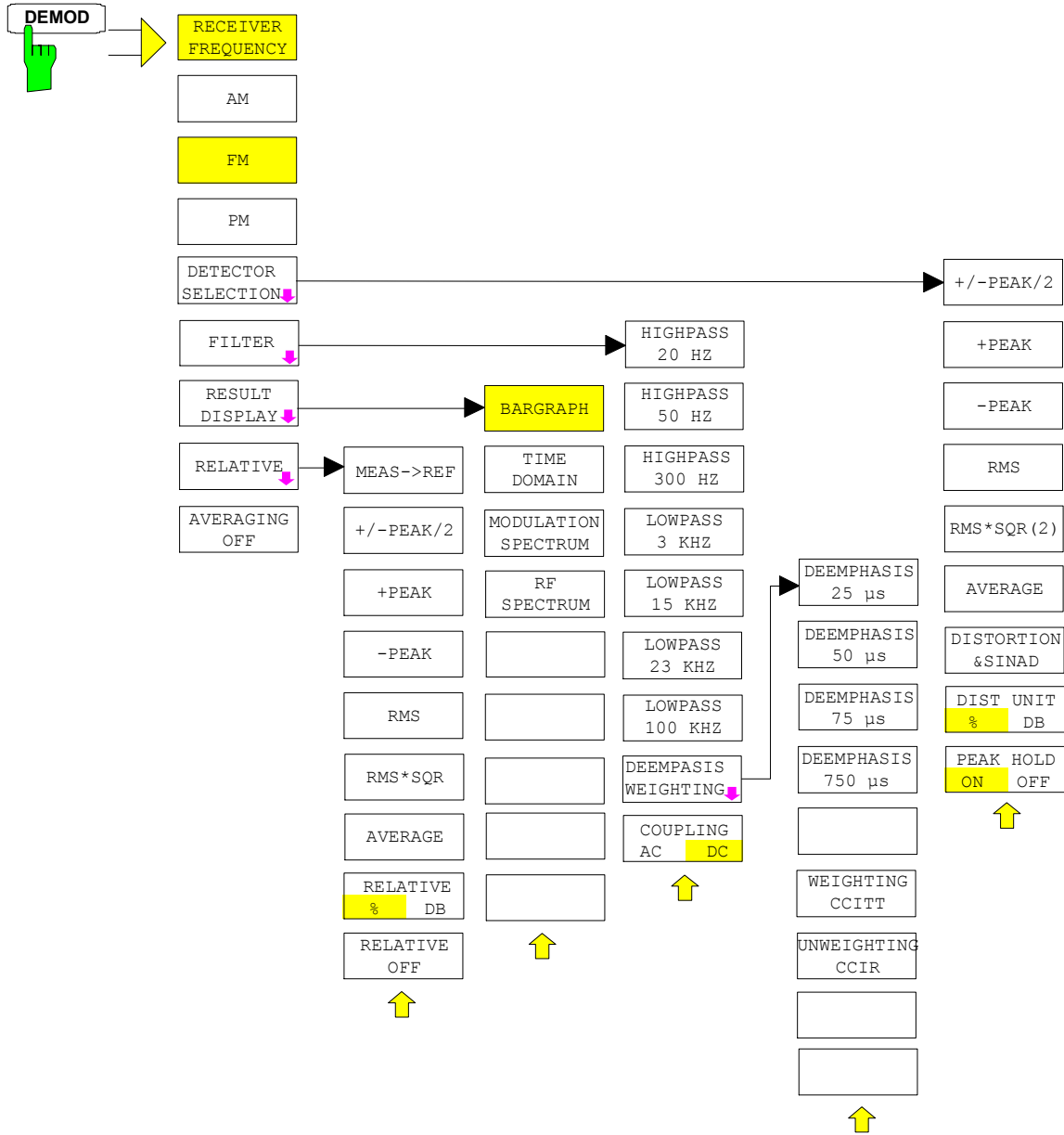

AUDIO Key

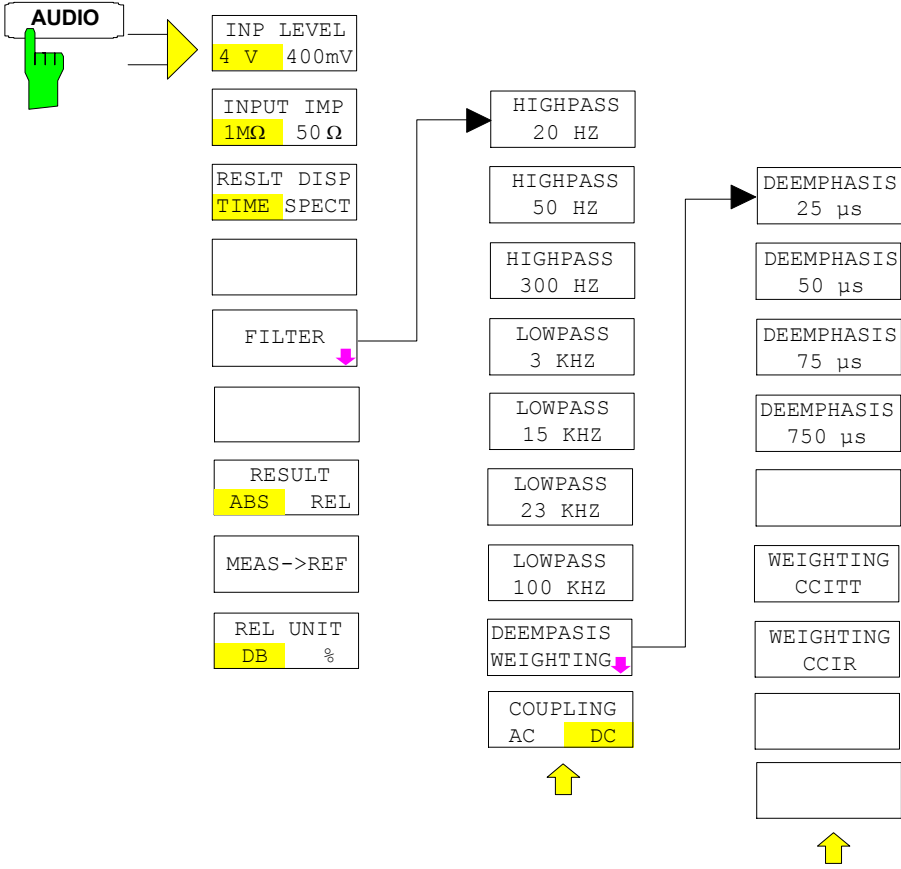

SPAN Key

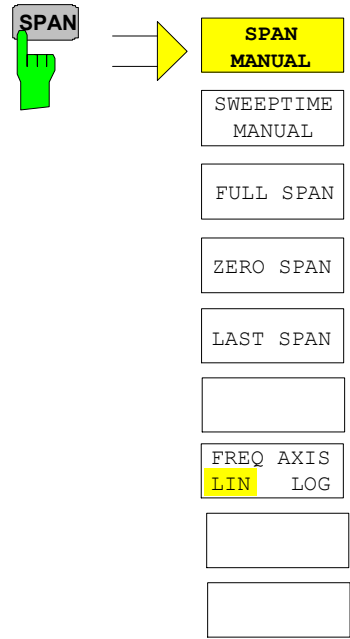

AMPT Key

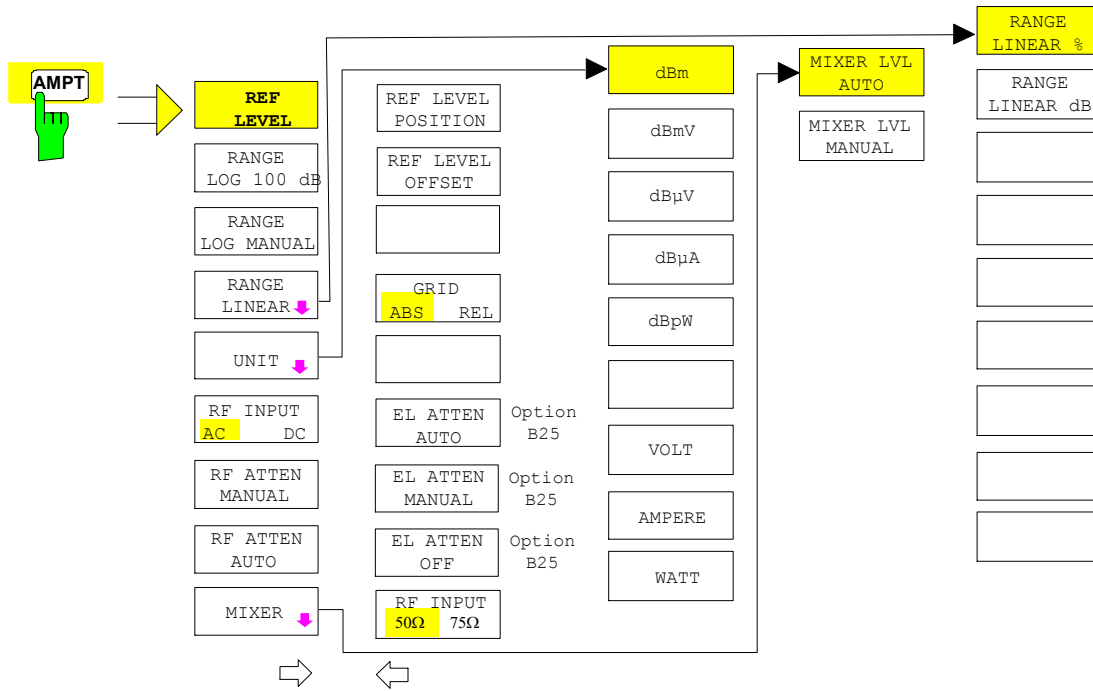

MEAS Key

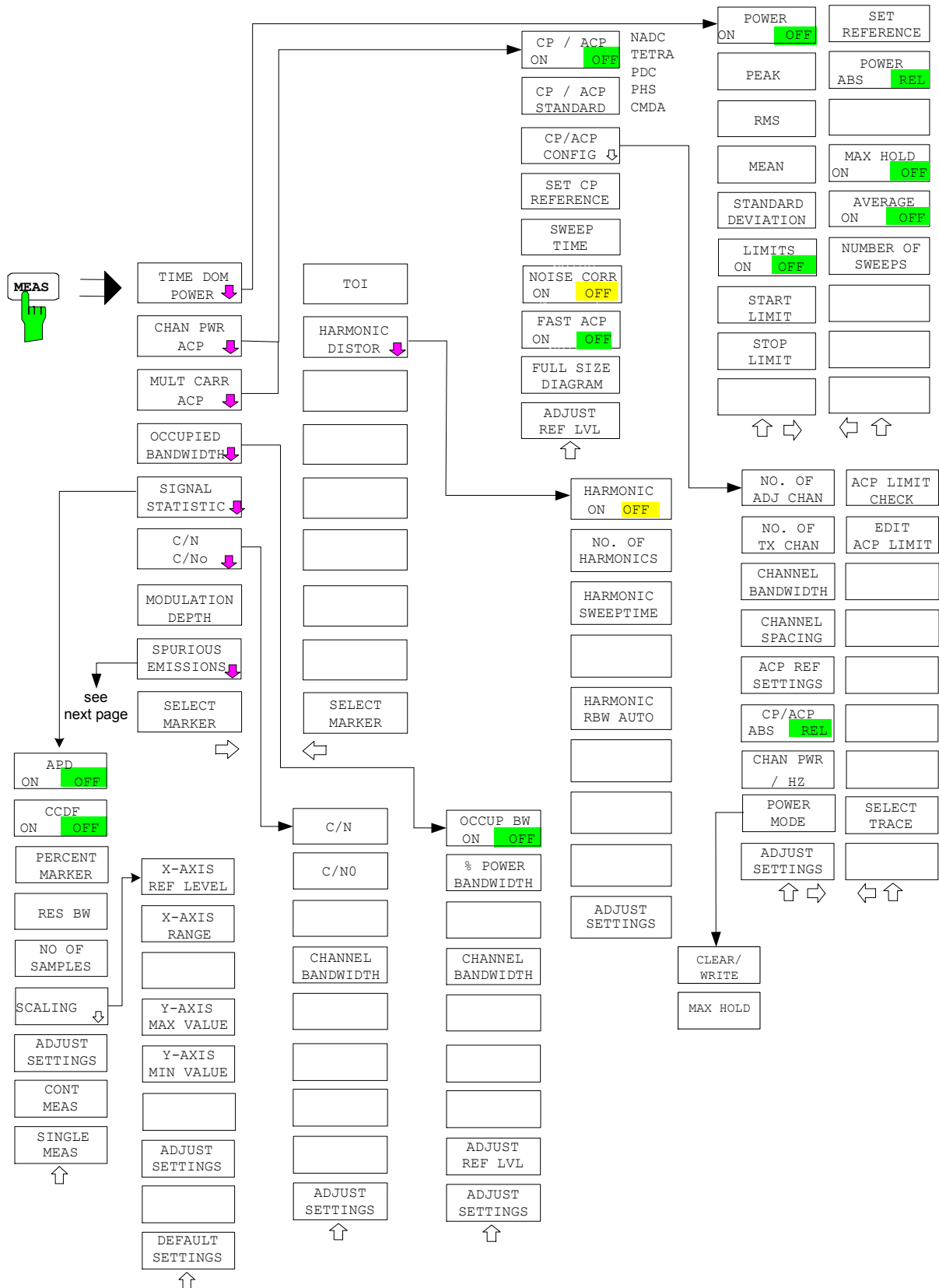

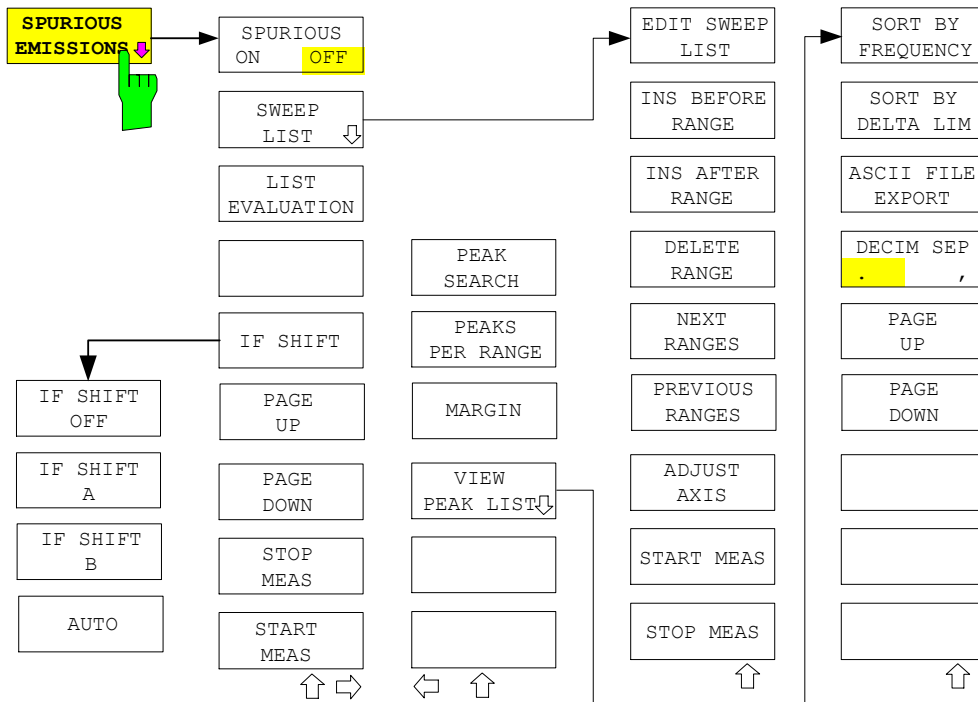

BW Key

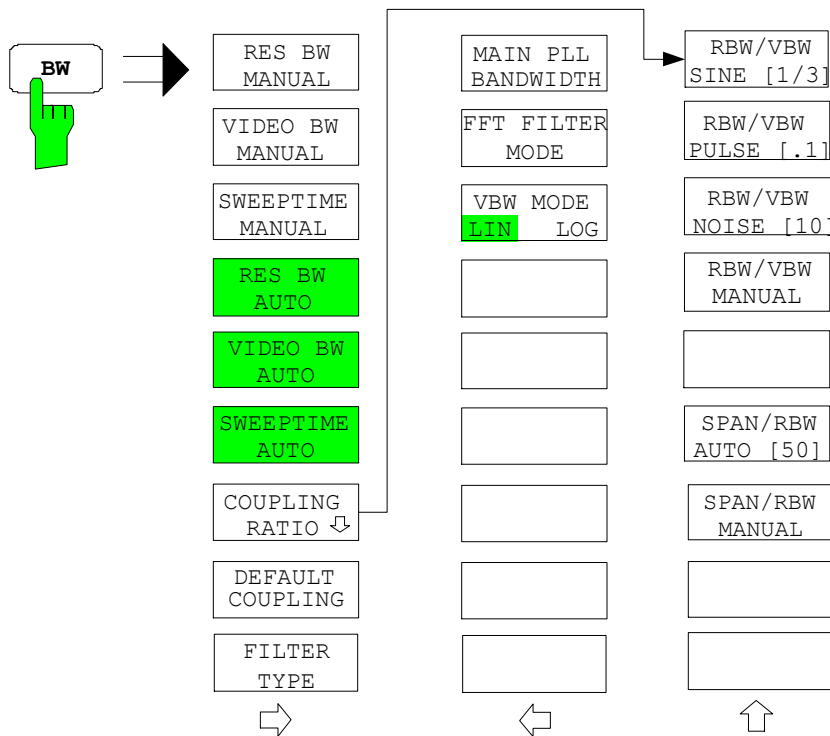

SWEEP Key

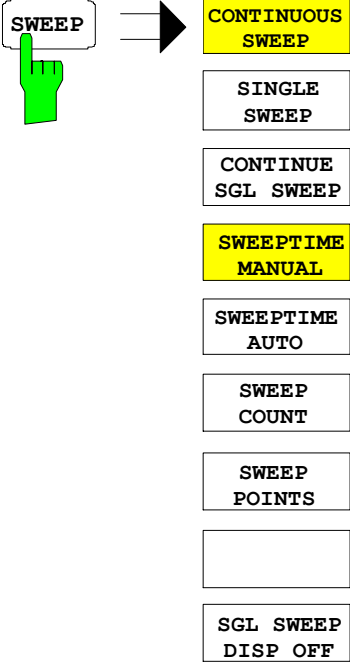

Menu Overview another Keys

MKR Key

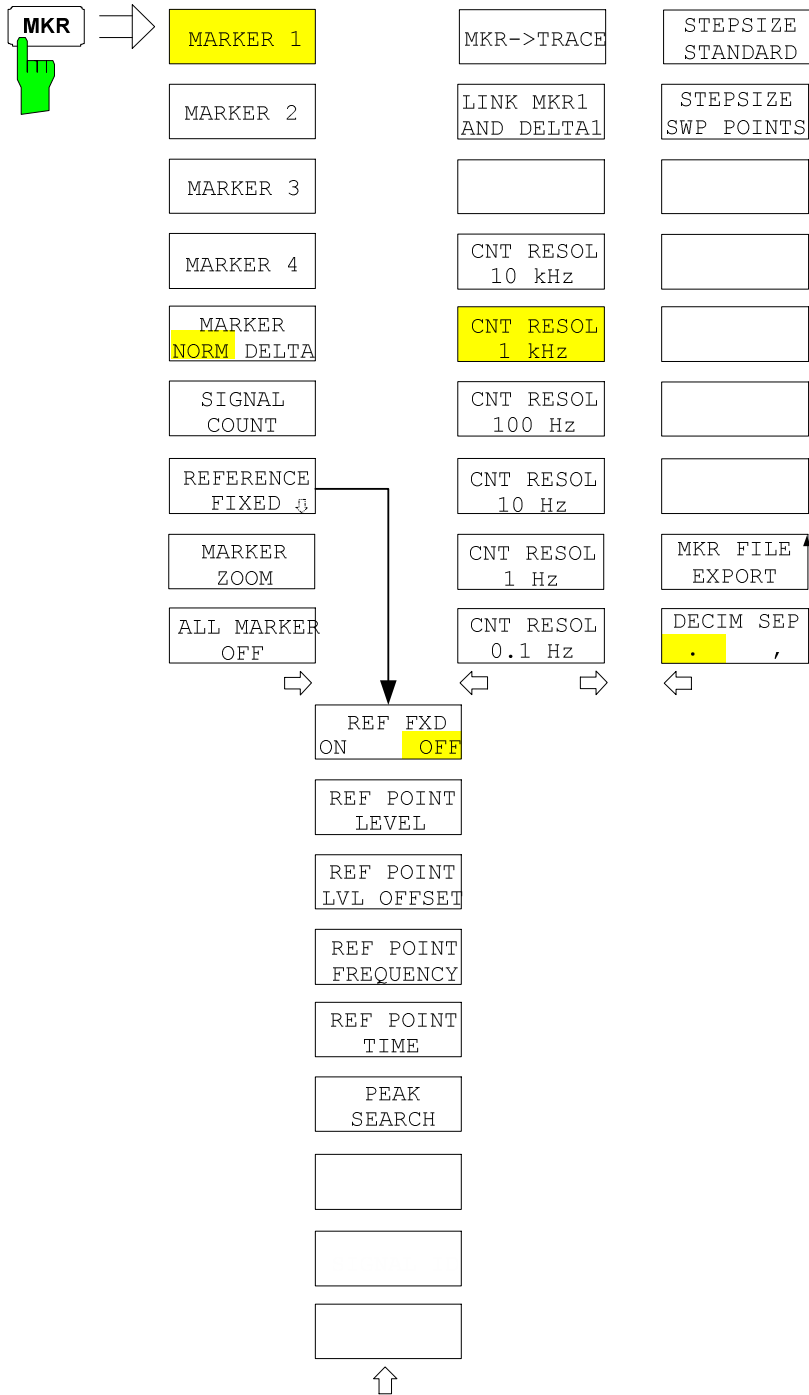

MKR-> Key

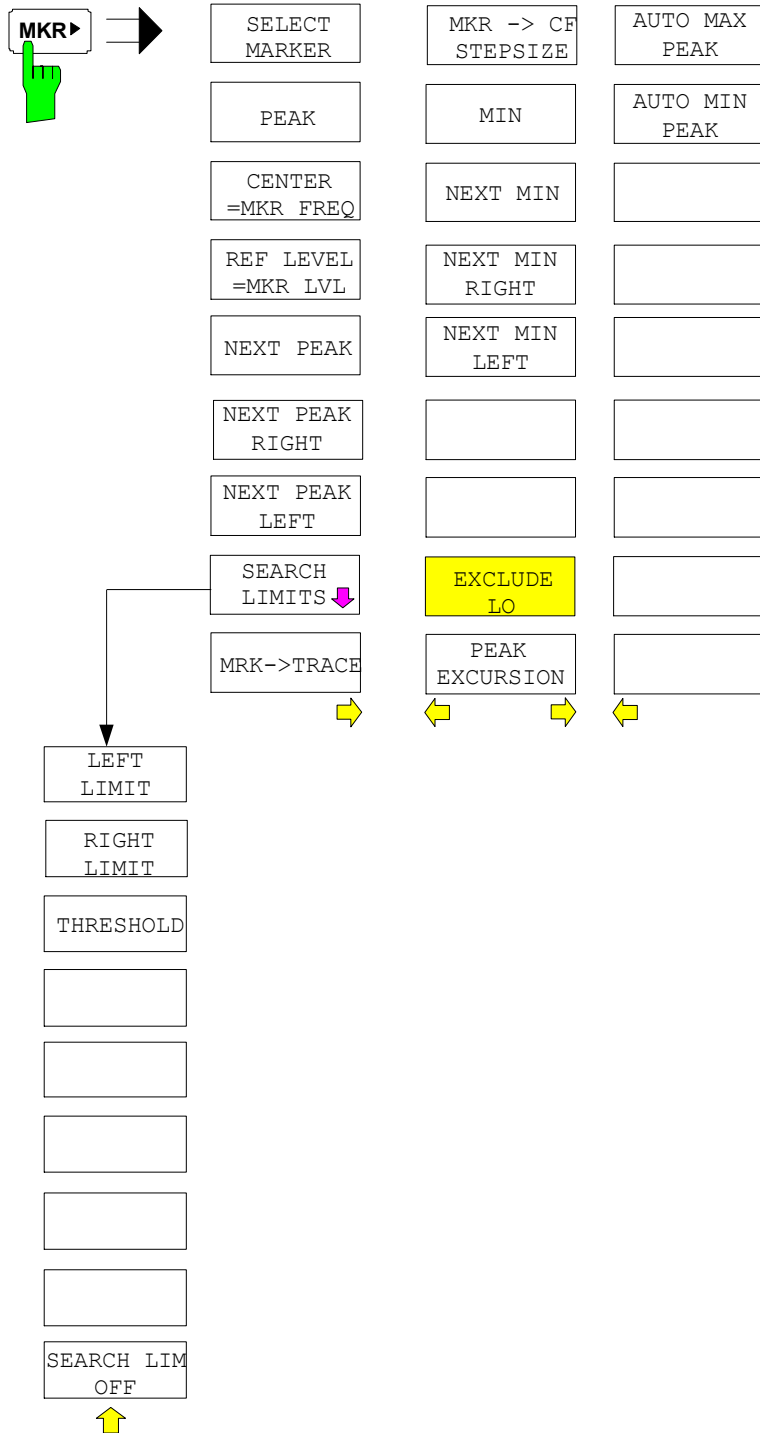

MKR FCTN Key

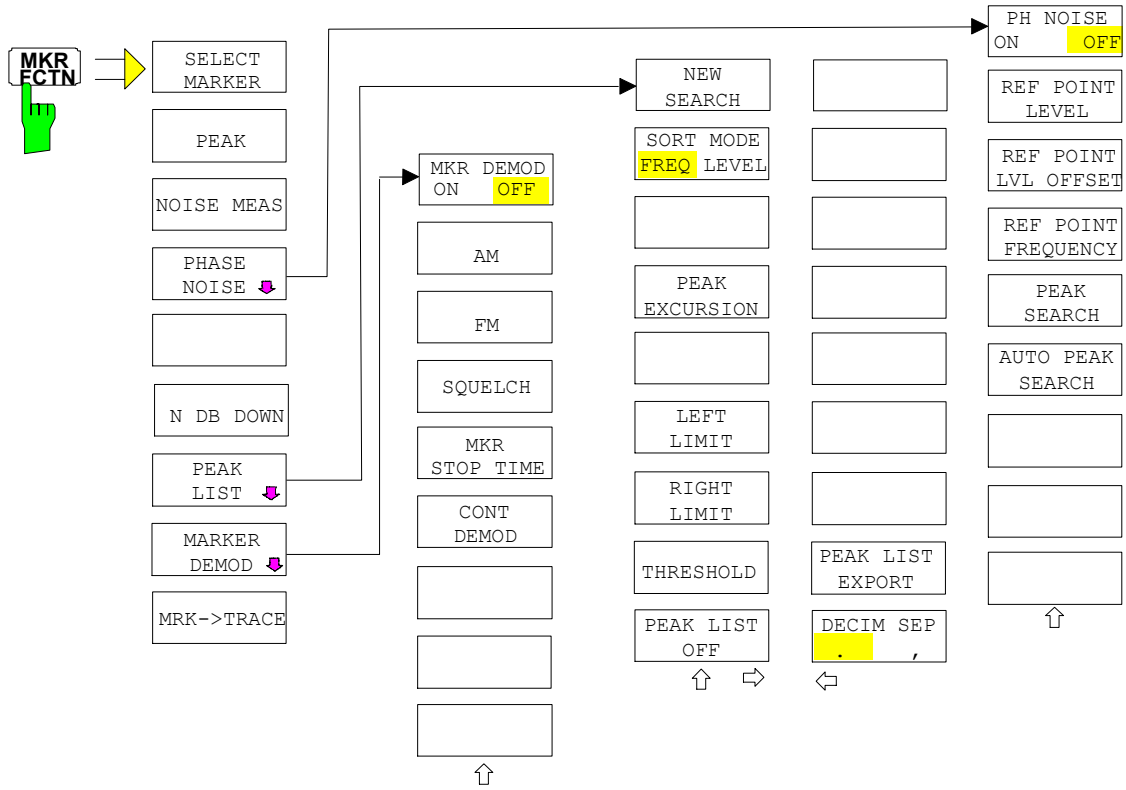

TRIG Key

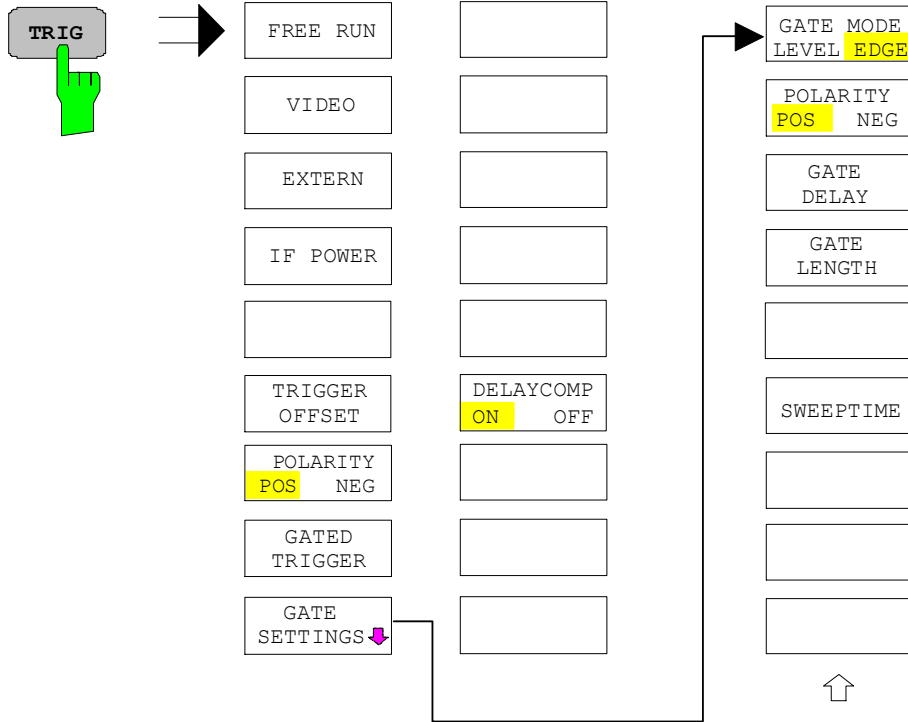

TRACE Key

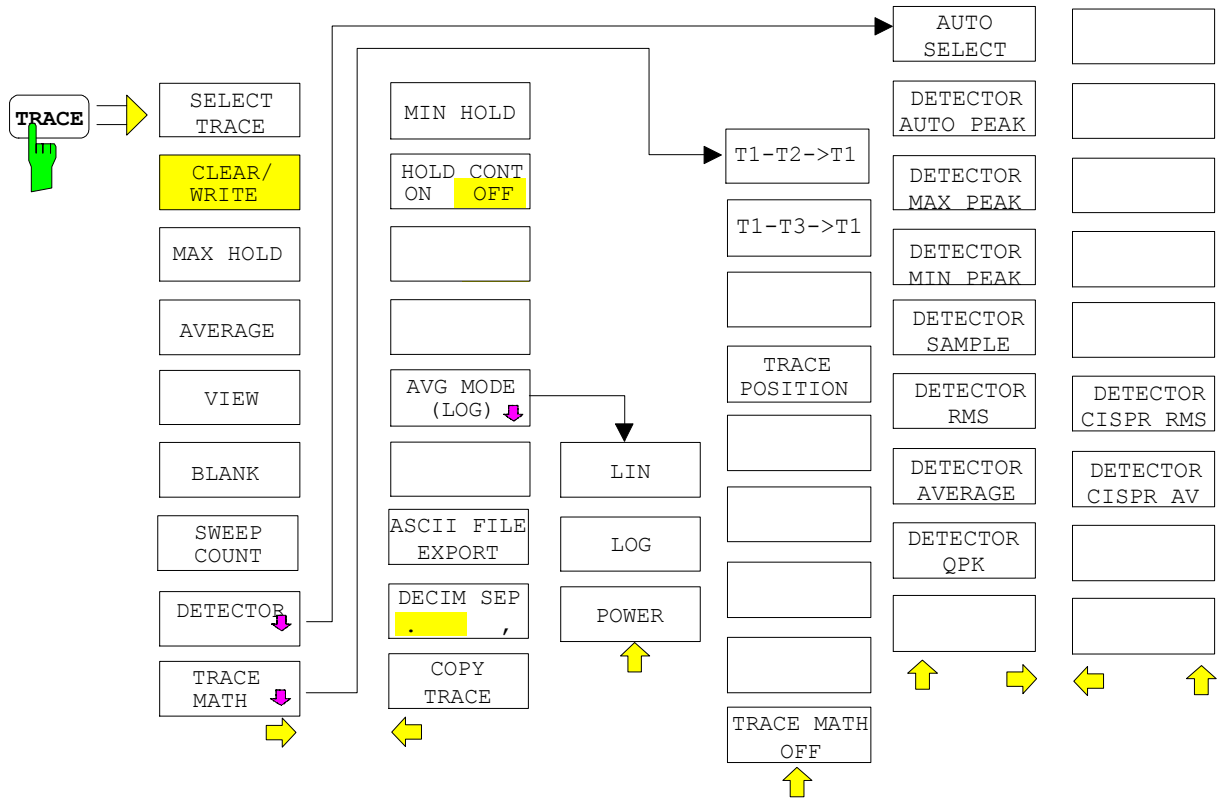

LINES Key

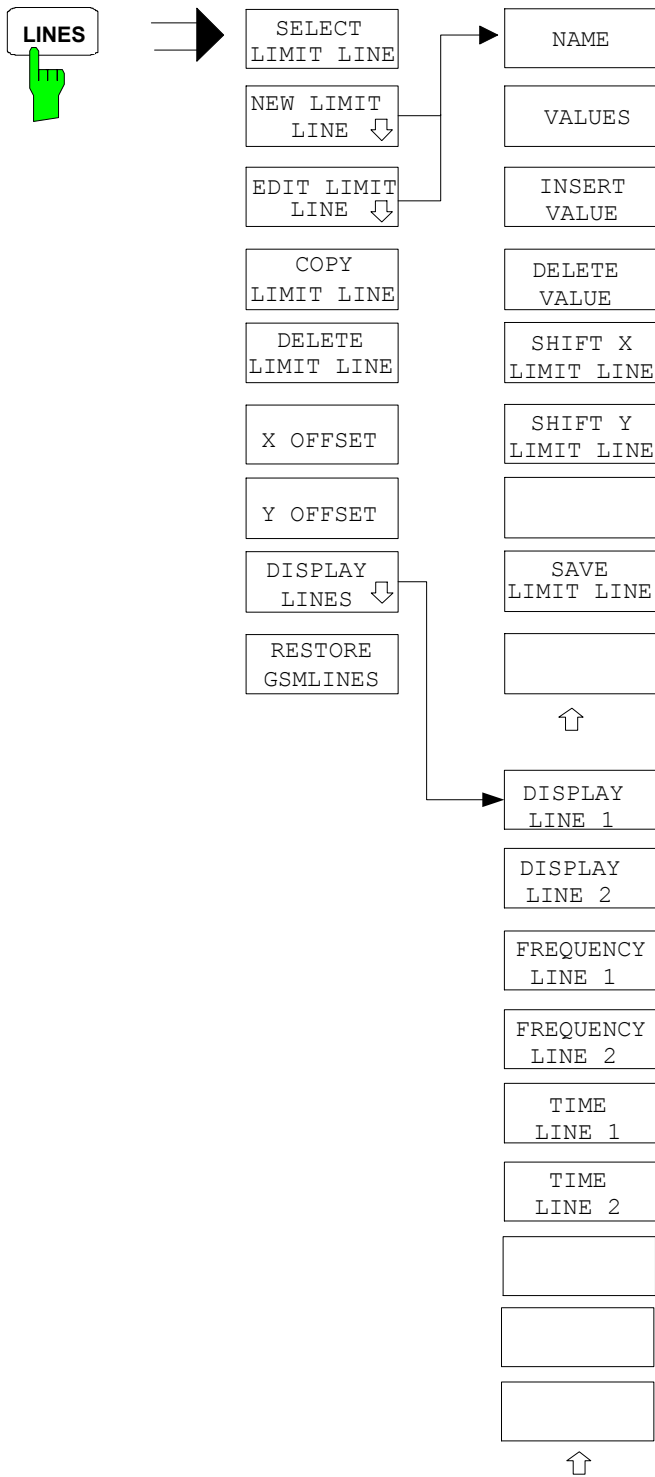

DISP Key

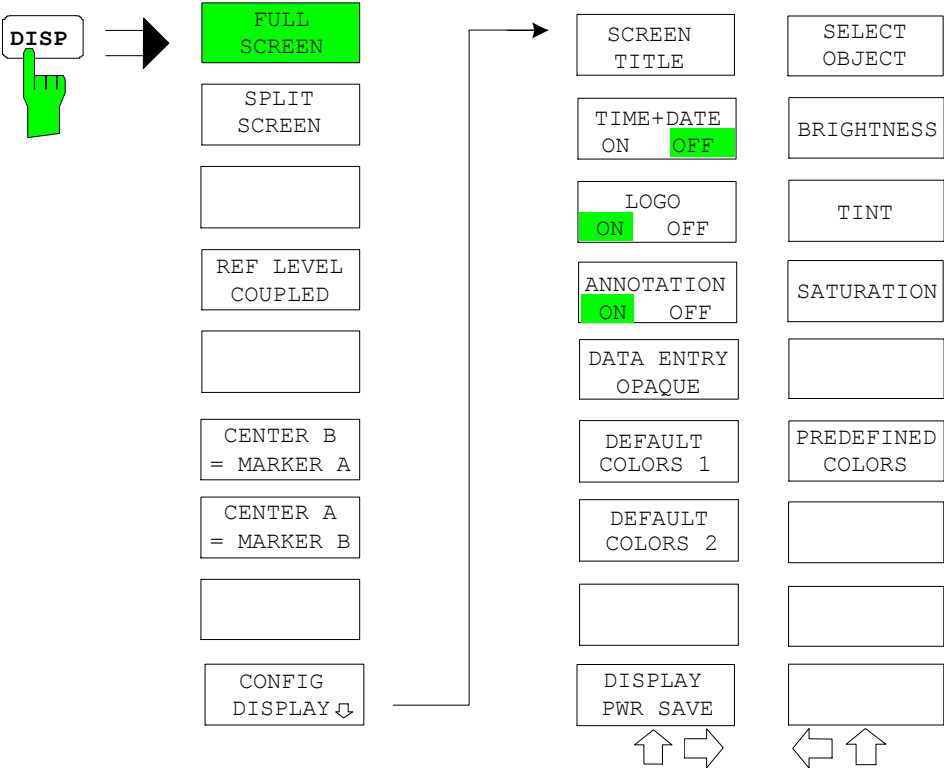

FILE Key

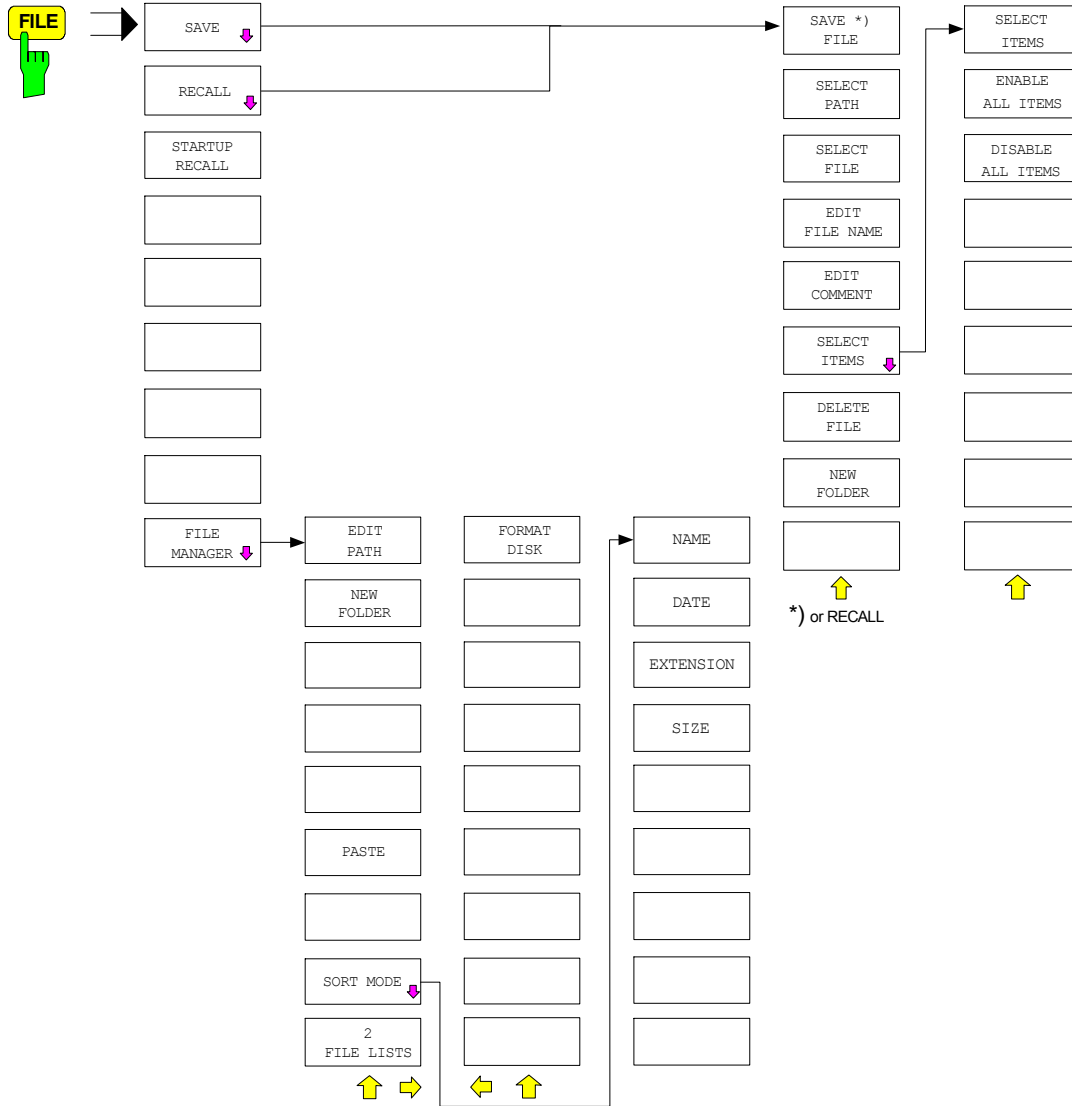

CAL Key

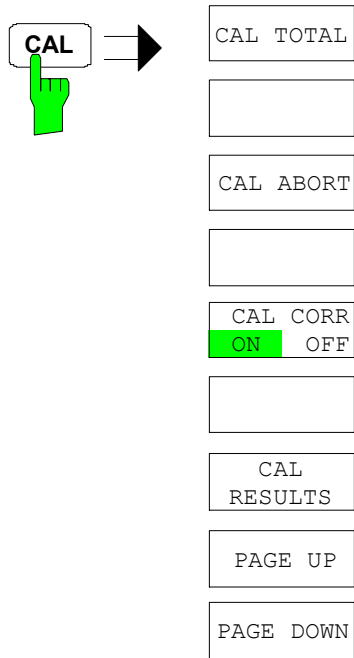

SETUP Key

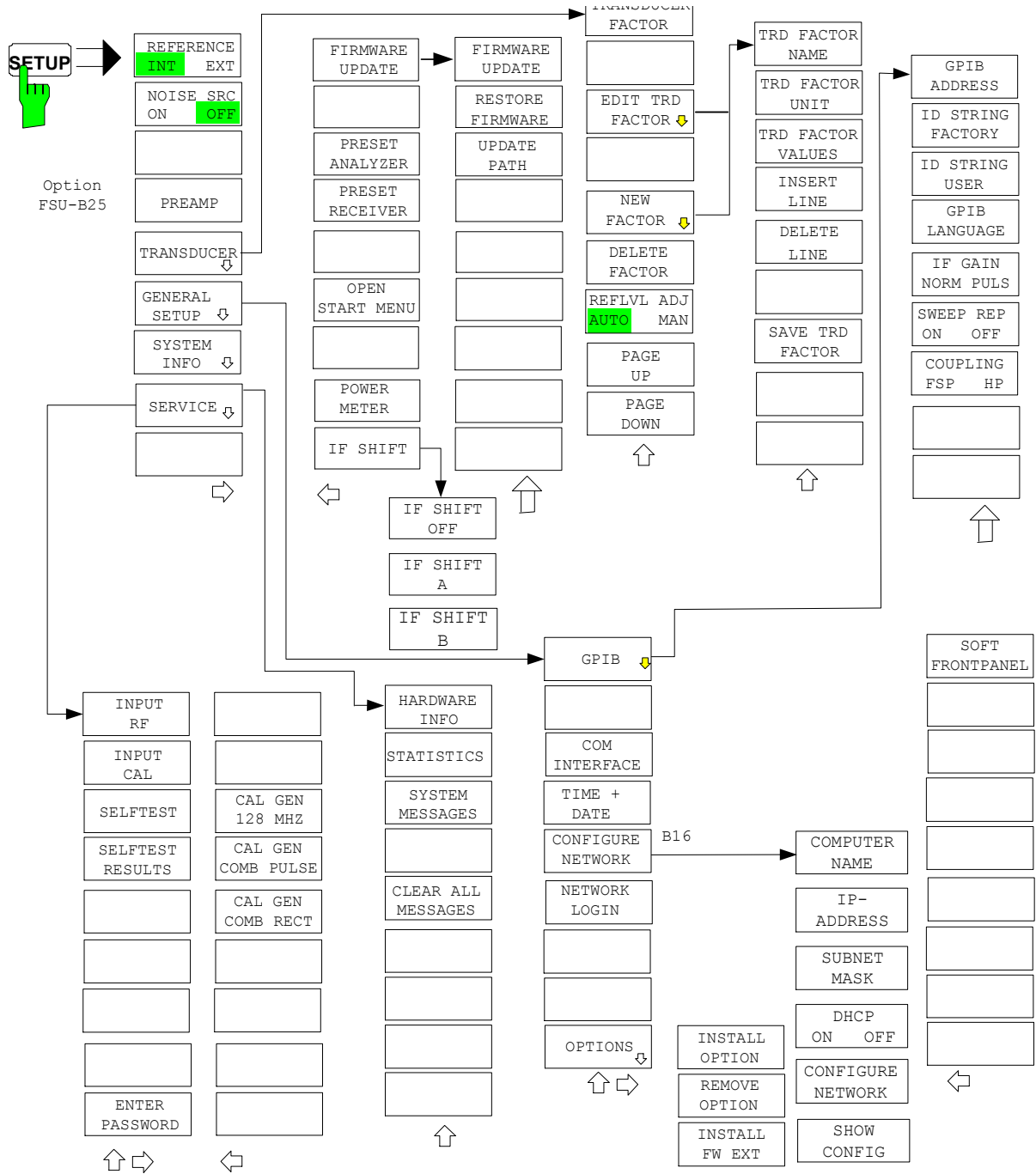

HCOPY Key

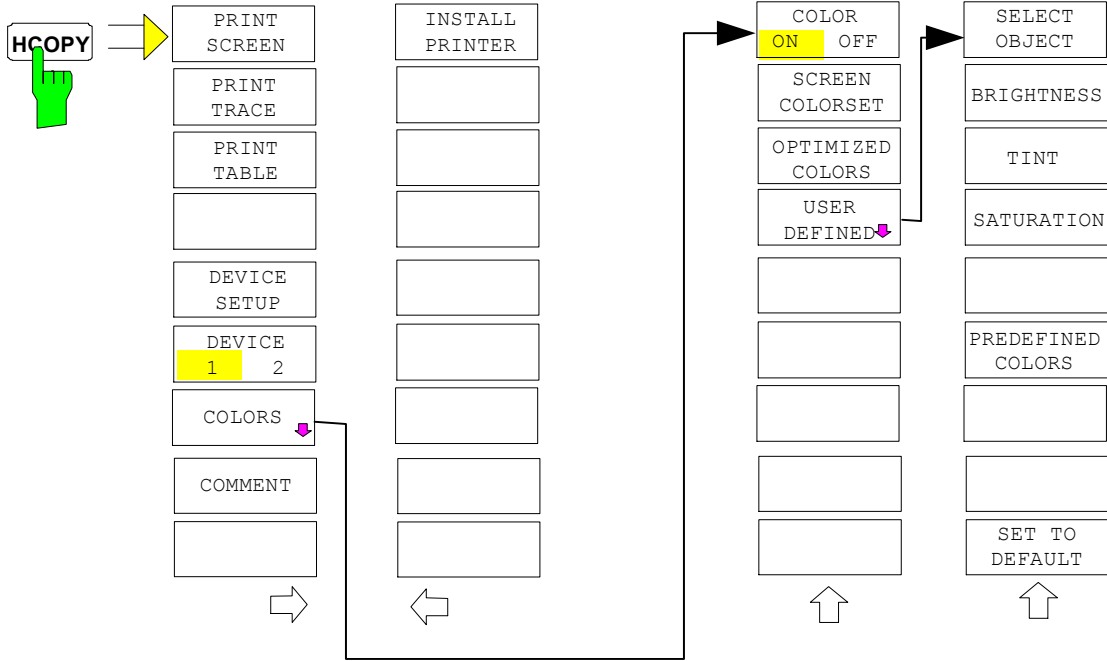

LOCAL Menu

Menu Overview Ext. Generator Control

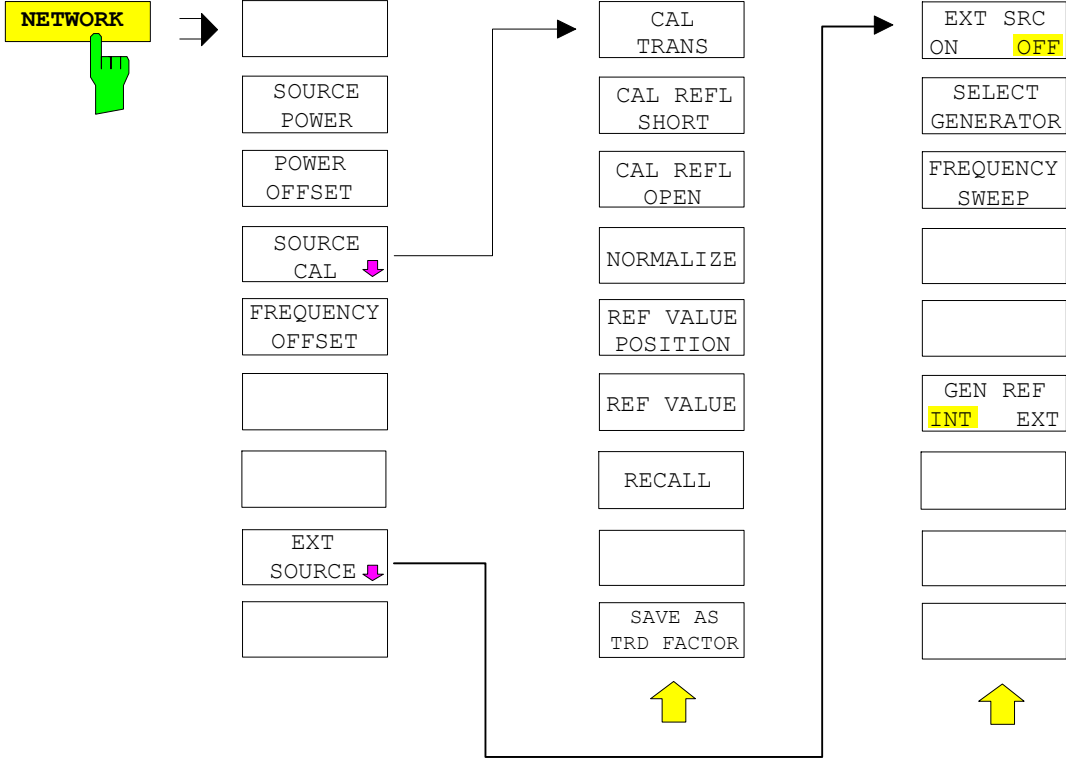

Menu Overview Option Network Mode

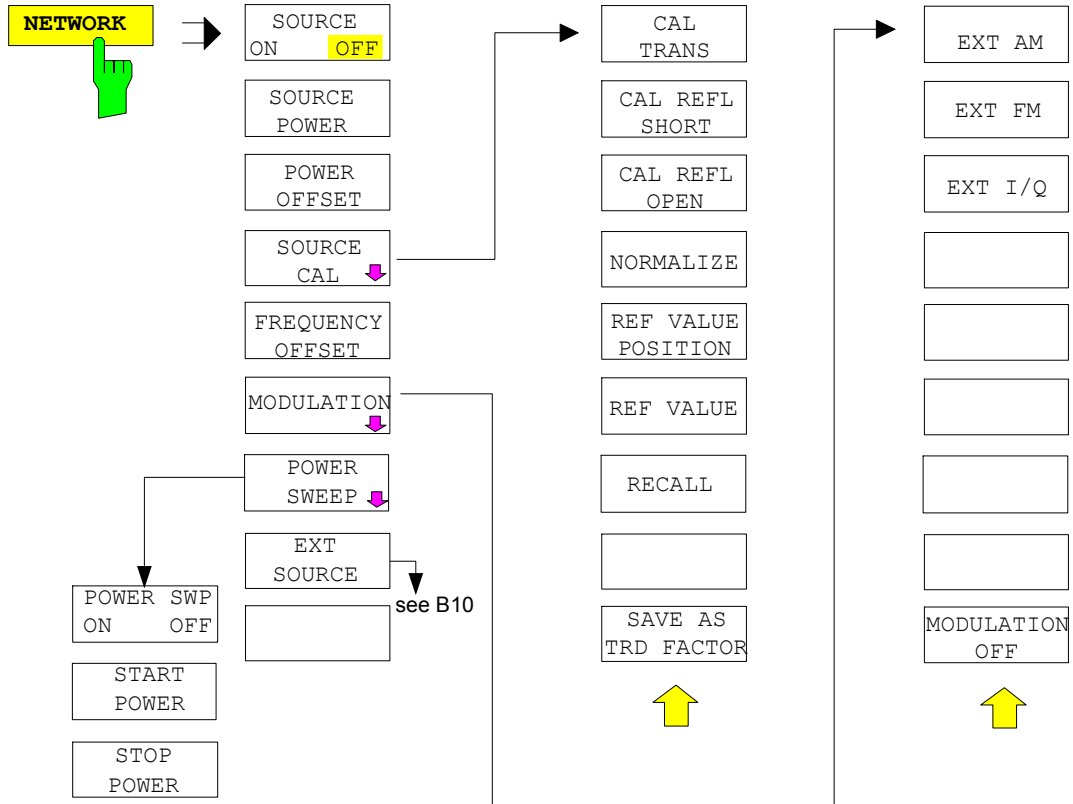

Index

* (enhancement label) 3.7

0

0 to 9 (key) 3.12

7

75 Ω (enhancement label) 3.7

A

AC supply connection 1.18

AP (trace info) 3.6

Windows XP: approved software 1.38

AV (trace info) 3.6

AVG (trace info) 3.6

B

BACK (key) 3.12

C

CANCEL (key) 3.12

CLWR (trace info) 3.6

Correction of entry 3.18

D

Decimal point 3.12

Display

power-save mode 1.20

Display mode

full screen 3.9

split screen 3.9

E

Editing

parameter 3.17

table 3.24

Electrostatic discharge 1.16

Enhancement labels 3.7

ENTER (key) 3.12

Entry

abort 3.12

activate 3.15, 3.26

correct 3.18

terminate 3.12

ESC (key) 3.12

EXT (enhancement label) 3.7

F

Frequency

axis labelling 3.4

FRQ (enhancement label) 3.7

Full screen 3.9

G

GAT (enhancement label) 3.7

Getting Started with the Instrument 1.16

GHz-dBm (key) 3.12

H

Hardware settings, indication 3.3

Help line editor 3.21

Hz/dB. (key) 3.12

I

IFOVL 3.5

Indication

hardware settings 3.3

instrument settings 3.7

marker information 3.4

K

Key

0 to 9 3.12

BACK 3.12

CANCEL 3.12

ENTER 3.12

ESC 3.12

GHz-dBm 3.12

Hz/dB 3.12

kHz/dB 3.12

MHz/dBm 3.12

spinwheel 3.13

kHz/dB (key) 3.12

L

Login/out (XP controller) 1.21

M

Marker

indication 3.4

MAXH (trace info) 3.6

Measurement

examples 2.1

Menu

call 3.11

change keys 3.11

Messages

acknowledgement	3.8
MHz/dBm (key).....	3.12
MI (trace info).....	3.6
MINH (trace info).....	3.6
Monitor	
connection	1.24

O

OVEN.....	3.5
OVLD.....	3.5

P

Parameter	
editing	3.17
selection.....	3.14
PK (trace info).....	3.6
Power-save mode	
display	1.20
hard disk	1.20
Preparing the Instrument for Operation	1.16
printer	
connect	1.25
PRN (enhancement lable)	3.7
Putting into operation	
AC supply connection	1.18

Q

QP (trace info).....	3.6
----------------------	-----

R

Rackmounting	1.17
RM (trace info)	3.6

S

SA (trace info).....	3.6
Screen.....	3.1
split screen.....	3.9
subdivision	3.2
Service Pack	1.21
Setting Up the Instrument.....	1.16
Settings, indication	3.7
SGL (enhancement lable).....	3.7
Sign (key).....	3.12
Softkey	
area	3.10
Spinwheel	3.13
Split screen	3.9
Status information	3.5
IFOVL	3.5
OVEN	3.5
OVLD.....	3.5
UNCAL.....	3.5
Switching on/off.....	1.18

T

T1-T2 (trace info).....	3.6
T1-T3 (trace info).....	3.6
Table	
operation	3.24
scrolling.....	3.26
Test	
functional.....	1.20
Trace info.....	3.6
TRG (enhancement lable).....	3.7

U

UNCAL	3.5
Unit (key)	3.12

V

VIEW (trace info)	3.6
-------------------------	-----

W

Windows XP	1.21
administrator ID	1.21
Windows-XP Servicepacks.....	1.21